



Directional Controls

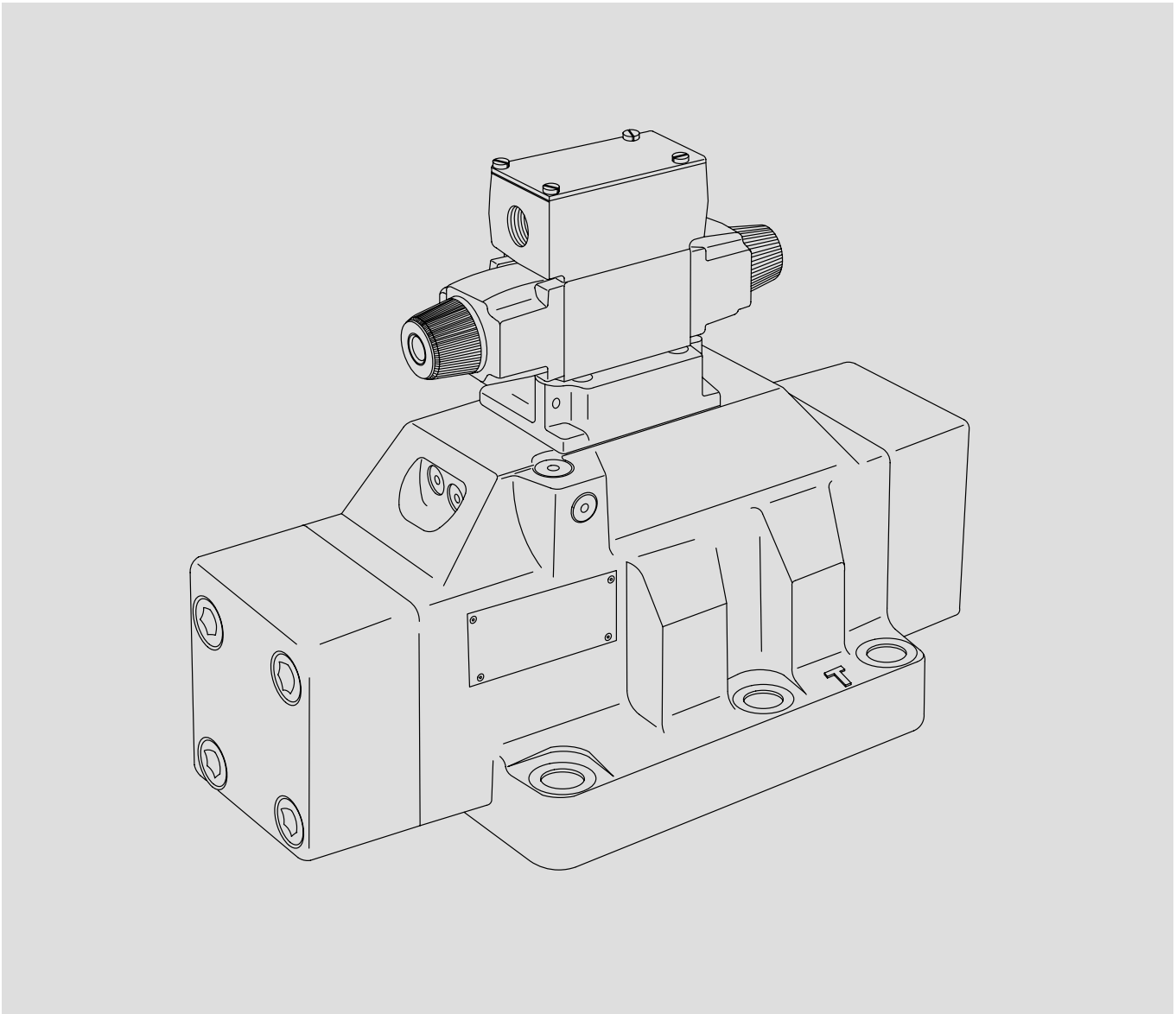

Table of Contents

Section	Page
I. Introduction	4
A. Purpose of Manual	4
B. General Information	4
II. Description	10
A. General	10
B. Basic Four-Way Sliding Spool Directional Valve Construction	10
C. Two Stage Directional Valve Construction	10
III. Valve Operation	11
A. General	11
B. Spool Types - Main Stage Section	11
C. Methods of Spool Control, Main Stage	12
D. Main Stage Spool Position	12
E. Optional Features (Main Stage)	16
IV. Pilot Valve Section	18
A. Spool Type - Pilot Valve Section	18
B. Spool Positioning - Pilot Valve Section	18
C. Methods of Control - Pilot Valve	19
V. Internal Valve Functions	23
A. General	23
B. Pilot Pressure	23
C. Pilot Valve Drains	23
D. Internal Check Valves	23
VI. Installation	24
A. Installation Drawings	24
B. Fluids and Seals	24
C. Piping and Tubing	24
D. Hydraulic Fluid Recommendations	24
E. Cleanliness	24
F. Overload Protection	24
VII. Service, Inspection & Maintenance	25
A. Service Tools	25
B. Inspection	25
C. Adding Fluid to the System	25
D. Adjustments	25
E. Replacement Parts	25
F. Product Life	25
G. Troubleshooting	25
VIII. Overhaul	26
A. Unit Removal	26
B. Disassembly	28
C. Pilot Valve Removal	28
D. Main Stage Disassembly	28
E. Pilot Valve Disassembly	28
F. Cleaning	34
G. Inspection, Repair and Replacement	34
H. Assembly	35
IX. Internal Body Passages and Plug Locations	37
X. Start-up and Test	38
A. Start-Up	38
B. Test	38

Section I – Introduction

A. Purpose Of Manual

This manual describes operational characteristics, maintenance requirements and overhaul information for Vickers DG3S4, DG4S4, DG4V, DG18V, DG19S and DF5S series single stage and two stage directional valves. The information contained herein pertains to the latest design series as listed in Table 1.

2. Model Codes - Variations within each basic model series are covered in the model code. Table 2 shows a complete breakdown of the model codes covering these units. Service inquiries should always include the complete model code number as stamped on the nameplate.

B. General Information

1. Related Publications - Service parts information and installation dimensions are not contained in this manual. The parts catalogs and installation drawings listed in Table 1 are available from your local sales or engineering office.

DF3S4-16**/DF5S4-16**/XDF5S4-16** SERIES

Model Description	50 Design	51 Design	53/54 Design	Additional Drawing	Installation Drawing	
DF3S4-16*A	I-3539-S				517100	
DF3S4-16*A			I-3555-S			
DF3S4-16*C	I-3539-S					
DF3S4-16*C			I-3561-S			
DF3S4-16*	I-3539-S					
DF3S4-16*			I-3561-S			
DF5S4-16*A-W(3)			I-3623-S			
DF5S4-16*A-*AC	I-3486-S					I-3499-S
DF5S4-16*A-*DC						I-3498-S
DF5S4-16*A-H						
DF5S4-16*			I-3622-S	518100		
DF5S4-16*B-W(3)			I-3623-S			
DF5S4-16*C-W(3)			I-3623-S			
DF5S4-16*C-*AC	I-3482-S					
DF5S4-16*C-*DC			I-3499-S			
DF5S4-16*C-H			I-3498-S			
DF5S4-16*C-*			I-3622-S			
DF5S4-16*N-W(3)			I-3623-S			
DF5S4-16*N-*AC	I-3482-S					
DF5S4-16*N-*DC			I-3499-S			
DF5S4-16*N-H			I-3498-S			
DF5S4-16*N-*			I-3622-S			
XDF5S4-16*A	I-3486-S			I-3501-S		
XDF5S4-16*C	I-3482-S					
XDF5S4-16*N		I-3482-S				

Table 1. Related Publications

DG17S/DG17S8/DG17/20V-3 SERIES

Model Description	10/11 Design	40 Design	50 Design	53 Design	Installation Drawing
DG17S4-012			I-3546-S		514500
DG17S4-012A			I-3546-S		514500
DG17S4-01*C/N			I-3546-S		514500
DG17S4-06A/C/N			I-3567-S		514705
DG17S4-10A/C/N			I-3568-S		514705
DG17S4-10A/C/N					
DG17/20V-3-*A*	I-3551-S	I-3872-S			514381
DG17/20V-3-*C*	I-3551-S				
DG17/20V-3-*N*	I-3632-S				
DG17S-8-*C					514701
DG17S-8-*N					514701

DG18S-8/DG18S2-*/DG18S4-*/DG18V-3 SERIES

Model Description	10/11 Design	40 Design	50 Design	51 Design	52 Design	Installation Drawing				
DG18S-8-*A	I-3442-S					516050				
DG18S-8-*C										
DG18S-8-*										
DG18S2-012N				I-3590-S	I-3554-S	516650				
DG18S2-012N										
DG18S4-01*A				I-3588-S						
DG18S4-01*C				I-3588-S						
DG18S4-01*C										
DG18S4-01*N				I-3589-S						
DG18S4-01*N					I-3590-S					
DG18S4-01*N							I-3554-S			
DG18S4-06*A							I-3587-S			
DG18S4-06*C							I-3587-S			
DG18S4-06*							I-3587-S			
DG18V3-A/B/C/F/N					I-3616-S					516061

DG19S4 SERIES

Model Description	50 Design	52 Design	70 Design	Installation Drawing
DG19S4-H06**		I-3574-S		517905
DG19S4-06*C	I-3588-S			
DG19S4-06**		I-3574-S		
DG19S4-10**	I-3537-S	I-3574-S		518005
DG19S4-04				
DG19S8				517906
DG19S-H8				
DG19SS4-10				518005

DG3S-H8/DG3S-8/DG3S4-04*/DG3S4-06*/DG3S4-10 SERIES**

Model Description	10/11 Design	20/21 Design	40 Design	51 Design	53/54 Design	Installation Drawing	
DG3S-H8-*A		I-3443-S				516320	
DG3S-H8-*C		I-3444-S					
DG3S-H8-**		I-3444-S					
DG3S-8-*A	I-3437-S					516300	
DG3S-8*C	I-3438-S						
DG3S-8*D	I-3436-S						
DG3S-8**	I-3438-S						
DG3S4-04**							I-3549-S
DG3S4-06*A							
DG3S4-06*C			I-3452-S	516800			
DG3S4-06*D			I-3457-S				
DG3S4-06*			I-3452-S				
DG3S4-10*A				I-3455-S	I-3563-S	517000	
DG3S4-10*C				I-3454-S	I-3626-S		
DG3S4-10*D				I-3456-S	I-3569-S		

Table 1. Related Publications (cont'd)

DG4S2/DG4S4 SERIES

Model Description	50 Design	51 Design	Installation Drawing	
DG4S2-012A-*AC	I-3478-S		517401	
DG4S2-012A-*DC	I-3507-S			
DG4S2-012A-H	I-3485-S			
DG4S2-012C-*AC	I-3477-S			
DG4S2-012N-*AC				I-3471-S
DG4S2-012N-*DC				I-3522-S
DG4S2-012N-H				I-3472-S
DG4S2-01*A-W(3)	I-3557-S	I-3559-S	517410	
DG4S2-01*N-W(3)				
DG4S4-01*A-*AC	I-3478-S		517401	
DG4S4-01*A-*DC	I-3507-S			
DG4S4-01*A-H	I-3485-S			
DG4S4-01*A-W(3)	I-3557-S		517410	
DG4S4-01*B-W(3)	I-3558-S			
DG4S4-01*C-*AC	I-3477-S		517401	
DG4S4-01*C-*DC	I-3506-S			
DG4S4-01*C-H	I-3483-S			
DG4S4-01*C-W(3)	I-3558-S			
DG4S4-01*N-*AC			I-3471-S	517401
DG4S4-01*N-*DC			I-3522-S	
DG4S4-01*N-H			I-3472-S	
DG4S4-01*N-W(3)			I-3559-S	517410

DG4V SERIES

Model Description	10 Design	11 Design	12 Design	40 Design	Installation Drawing
DG4V-3-*A(P)/B(P)/C	I-3529-S				517350 (10-12 Design)
DG4V-3-*A(P)			I-3629-S	I-3861-S	
DG4V-3-*B(P)			I-3630-S	I-3862-S	
DG4V-3-*C			I-3630-S	I-3863-S	
DG4V-3-*F(P)			I-3619-S	I-3864-S	
DG4V-3-*N			I-3529-S	I-3865-S	
DG4V-3-*N			I-3631-S		517351 (-40 Design)

Table 1. Related Publications (cont'd)

DG5S-H8/DG5S-8/DG5S4-H06/DG5S4-06**/DG5S4-10**/XDG5S4-06**/XDG5S4-10** SERIES**

Model Description	10/11 Design	20/21 Design	40 Design	50 Design	51 Design	53/54 Design	70 Design	Addl. Drawing	Installation Drawing
DG5S-H8-*A/B/C/N		I-3445-S							517930
DG5S-8-*A/B/C/N	I-3439-S	I-3869-S							517840
DG5S-8-*D	I-3440-S	I-3873-S							
DG5S4-H06*A-M					I-3446-S				517850
DG5S4-H06*A-*AC					I-3459-S				517920
DG5S4-H06*C-M					I-3447-S				517850
DG5S4-H06*C-*AC					I-3458-S				517920
DG5S4-H06*D					I-3460-S				
DG5S4-H06*N-M					I-3448-S				517850
DG5S4-H06*N-*AC					I-3461-S				517920
DG5S4-04*A/B/C/N			I-3548-S						517810
DG5S4-06*A				I-3492-S					517900
DG5S4-06*A-M					I-3468-S				517850
DG5S4-06*A-*AC									
DG5S4-06*A-*DC					I-3502-S			I-3499-S	517900
DG5S4-06*A-H								I-3498-S	
DG5S4-06*C				I-3490-S					
DG5S4-06*C-M					I-3469-S				517850
DG5S4-06*C-*AC					I-3473-S				
DG5S4-06*C-*DC					I-3473-S			I-3499-S	517900
DG5S4-06*C-H					I-3473-S			I-3498-S	
DG5S4-06*D				I-3493-S					
DG5S4-06*D-*AC									
DG5S4-06*D-*DC						I-3504-S		I-3499-S	
DG5S4-06*D-H								I-3498-S	
DG5S4-06*N				I-3491-S					
DG5S4-06*N-M					I-3470-S				517850
DG5S4-06*N-*AC/DC					I-3474-S			I-3499-S	517900
DG5S4-10*N-H					I-3474-S			I-3498-S	
DG5S4-10*A				I-3496-S					518000
DG5S4-10*A-M					I-3449-S	I-3621-S	I-3870-S		518100
DG5S4-10*A-W(3)						I-3627-S			
DG5S4-10*A-*AC									
DG5S4-10*A-*DC					I-3513-S			I-3499-S	518000
DG5S4-10*A-H								I-3498-S	
DG5S4-10*A-*						I-3624-S			
DG5S4-10*B-M						I-3621-S			518100
DG5S4-10*B-W(3)						I-3627-S			
DG5S4-10*B-*						I-3624-S			518000
DG5S4-10*C				I-3494-S					
DG5S4-10*C-M					I-3450-S	I-3621-S			518100
DG5S4-10*C-W(3)						I-3627-S			
DG5S4-10*C-*AC									
DG5S4-10*C-*DC					I-3509-S			I-3499-S	518000
DG5S4-10*C-H								I-3498-S	
DG5S4-10*C-*						I-3624-S			
DG5S4-10*D				I-3497-S					
DG5S4-10*D-W(3)						I-3628-S			
DG5S4-10*D-*AC									
DG5S4-10*D-*DC					I-3514-S			I-3499-S	518000
DG5S4-10*D-H								I-3498-S	
DG5S4-10*D-*						I-3625-S			
DG5S4-10*N				I-3495-S					
DG5S4-10*N-M					I-3451-S	I-3621-S			518100

Table 1. Related Publications (cont'd)

DG5S-H8/DG5S-8/DG5S4-H06/DG5S4-06**/DG5S4-10**/XDG5S4-06**/XDG5S4-10** SERIES**

Model Description	10/11 Design	20/21 Design	40 Design	50 Design	51 Design	53/54 Design	70 Design	Add. Drawing	Installation Drawing
DG5S4-10*N-W(3)						I-3627-S			518000
DG5S4-10*N-*AC					I-3512-S		I-3499-S		
DG5S4-10*N-*DC							I-3498-S		
DG5S4-06*N-*H									
DG5S4-06*N-*						I-3624-S			
XDG5S4-06*A					I-3502-S			I-3501-S	517900
XDG5S4-06*C					I-3473-S				
XDG5S4-06*D					I-3504-S				
XDG5S4-06*N					I-3474-S				
XDG5S4-10*A					I-3513-S				
XDG5S4-10*C					I-3509-S				518000
XDG5S4-10*D					I-3514-S				
XDG5S4-10*N					I-3512-S				

Table 1. Related Publications (cont'd)

Model Code

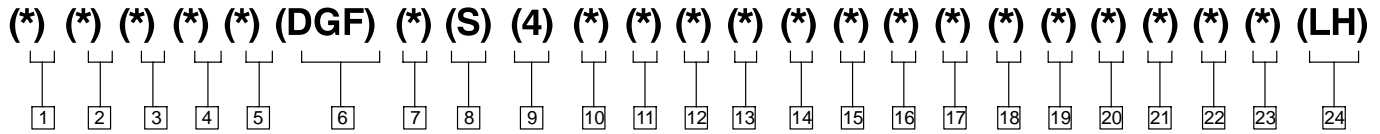

- | | | |
|---|--|---|
| <p>1 F3 Viton Seals
(omit for standard models)</p> <hr/> <p>2 X - Hazardous
Location Solenoid
(omit if not required)</p> <hr/> <p>3 XM - Mining Applications
(omit if not required)</p> <hr/> <p>4 Electrical Plug Feature
(omit if not required)
PB - Insta-Plug Male/Female
Connection
PA3 - 3 pin
PA5 - 5 pin</p> <hr/> <p>5 S - Monitor Switch Feature
(omit if not required)</p> <hr/> <p>6 Model Series
DGF - Directional control, manifold
or subplate mounting, flange</p> <hr/> <p>7 Control Type
4 - Elect. solenoid
5 - Pilot - elect. solenoid
17 - Manual lever
18 - Air pressure
19 - Pilot - air pressure</p> <hr/> <p>8 Spool
S - Slide spool
(rated pressure 320 bar, 3000 psi)
V - Sliding spool
(rated pressure 345 bar, 5000 psi)</p> <hr/> <p>9 Flow Direction
4 - Four-way (omit for DG5S-8
& DG5S-H8 models)</p> <hr/> <p>10 Electrical Accessories
L - Solenoid indicator lights
W - Wiring housing</p> <hr/> <p>11 H - High flow
(omit for standard models)</p> <hr/> <p>12 Series
04 - 1/2" (12 to 25 USgpm rated flow)
06 - 3/4" (45 USgpm rated flow)
H06 - 3/4" (80 USgpm rated flow)
10 - 1 1/4" (100 USgpm rated flow)
16 - 2" (200 USgpm rated flow)
interface (10/20 design models)
(ISO-4401-8 (NFPA-D06)
8 - 170 liters (45 USgpm rated flow)
H8 - 265 liters (70 USgpm rated flow)</p> | <p>13 Spool Type - Main Stage Section
0 - Open center
1 - Open center, P-A
2 - Closed center
3 - P & B blocked in center
4 - Tandem center, closed crossover
6 - P blocked in center
7 - P, A & B interconnected,
T blocked
8 - Tandem center, open center
crossover
9 - Open center over tapers
31 - Closed center, P-A
33 - P blocked, A & B bleed to tank</p> <hr/> <p>14 Pilot Pressure Range
(pressure centered "D" models only)
A - 200-1000 psi
B - 1000-2000 psi
(omit - 2000-3000 psi)</p> <hr/> <p>15 Valve Type
A - Spring offset (one solenoid)
B - Spring centered (one solenoid)
C - Spring centered
D - Pressure centered
F - Spring offset to "A" port
N - No spring-detented
(omit on no-spring,
"floating" models)</p> <hr/> <p>16 X - Fast Response Model
(omit on standard low shock
models)</p> <hr/> <p>17 Spool Control Modification
(omit if not required)
1 - Stroke adjustment
2 - Pilot choke adjustment
3 - Pilot choke and stroke adjustment
7 - Stroke adjustment -
cylinder "A" end only
8 - Stroke adjustment -
cylinder "B" end only</p> <hr/> <p>18 E - External Pilot Drain
(omit if not required)</p> <hr/> <p>19 T - Internal Pilot Drain
(omit - external pilot drain)</p> <hr/> <p>20 Check Valve in Pressure Port
(omit if not required)
K - 0.35 bar (5 psi) cracking press
R - 3.45 bar (50 psi) cracking press
S - 5.20 bar (75 psi) cracking press</p> | <p>21 Pilot Valve and/or Solenoid Type
M - DG4V-3 pilot valve and adapter
plate (omitted on DG5S-8
(DG5S-H8 models)
H - Oil immersed solenoid
W - Nonserviceable core tube,
wet armature solenoids only
W3 - Serviceable core tube, wet
armature solenoids only</p> <hr/> <p>22 Coil Identification & Voltage Range
(pilot valve)
B - 115/120 Vac 60 Hz & 110 Vac 50 Hz
(8 & H8 series only)
D - 230 Vac 60 Hz & 220/230 Vac 50 Hz
F - 6 Vdc
G - 12 Vdc
H - 24 Vdc
M - 450 Vac 50 Hz & 460 Vac 60 Hz
(omit on standard
115 Vac 60 Hz models)</p> <hr/> <p>23 Design
10 - DG5S-8 models only
20 - DG5S-H8 models only
40 - 04 models & dg4v-3 pilot,
DG18V-3 pilot
50/52 - standard models
53 - Latest design, SAE straight
thread construction plug
70 - DG5S4-10 & DG19S4-10 only</p> <hr/> <p>24 Left Hand Assembly
(single solenoids only)
(Omit for standard right hand models)</p> |
|---|--|---|

Table 2. Model Code Breakdown

Section II – Description

A. General

Directional valves are devices used to change the flow direction of fluid within a hydraulic circuit. A valve is designed to control the direction of movement of a work cylinder or the direction of rotation of a fluid motor.

B. Basic Four-Way Sliding Spool Directional Valve Construction

Vickers valve bodies have a precision machined bore in which a very close tolerance spool is suspended on a film of hydraulic fluid. Spool lands and body cavities are designed to divide the bore openings into separate chambers. Ports in the body lead into these chambers so that spool position determines which ports are open or closed. See Figure 1. Oil flow is directed from one port to another within the body and out of a port to the work.

C. Two Stage Directional Valve Construction

Two stage directional valves are pilot pressure operated. A two stage valve is constructed by combining a pilot valve and a larger main stage valve into one assembly. The pilot valve, usually a DG4S4-01, DG4V-3 or DG18V-3 is mounted on top of the main stage valve. The pilot valve controls spool movement within the main stage section. Pilot spool movement is normally, actuated by electrical solenoids. When a solenoid is energized (activated), the pilot spool moves and fluid is diverted to the main stage; thus controlling main stage spool movement, Figure 2 illustrates the basic construction of a two stage, pilot operated directional valve.

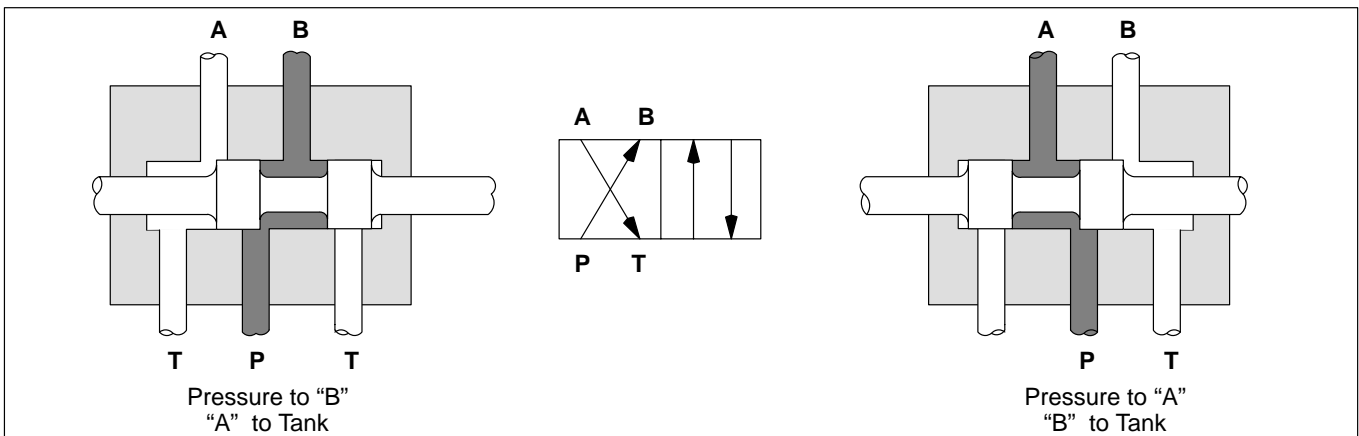

Figure 1. Spool Type Four-Way Valve

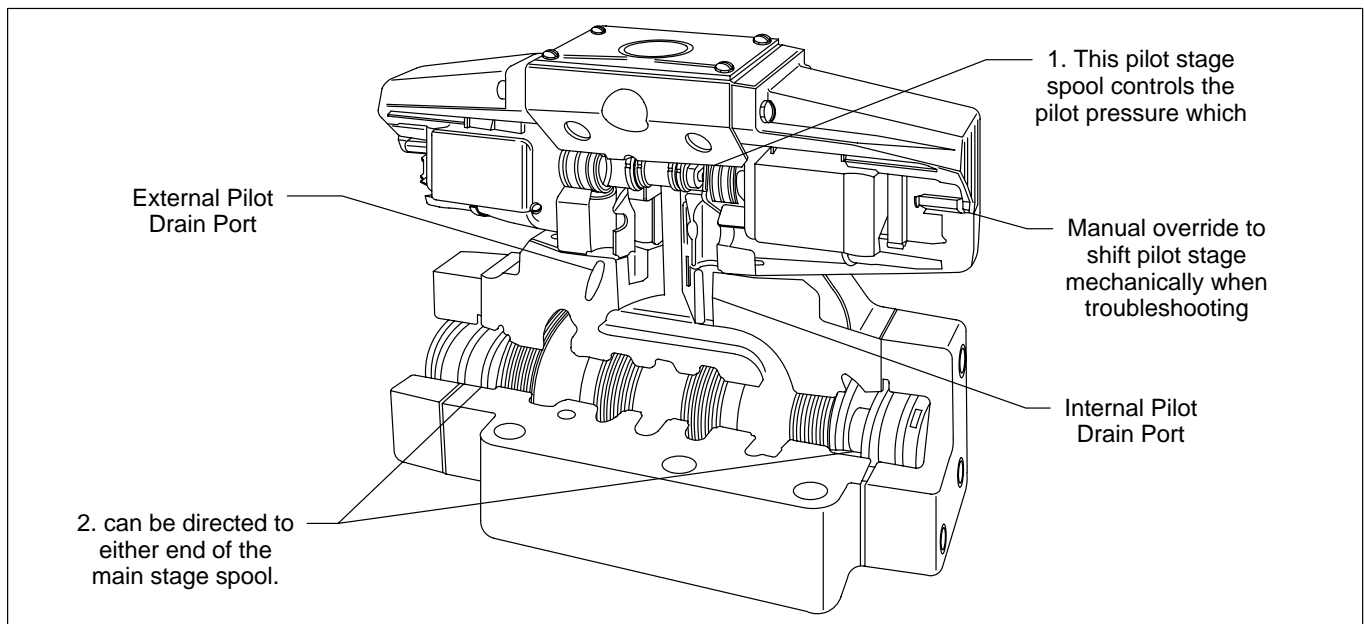

Figure 2. Typical "DG5" Type Solenoid Controlled, Pilot Operated Valve

Section III – Valve Operation

A. General

Directional Valve operation is determined by four factors; spool type, spool positioning, method of control, and special features. Proper selection of the above factors establish and regulate desired flow paths through the internal ports of the valve. The following information discusses those factors with respect to valve operations.

B. Spool Types - Main Stage Section

Operation of spools are governed by their design as well as the means of control. The most common designs are open center, closed center and tandem. During the following discussion, basic spool design is related to valve port openings, with the spool in center position. Port openings are stated as: P - Pressure Port, A & B - Actuator Ports, and T - Tank or Reservoir Port. Refer to Figure 3.

1. **Open Center Spools (0, 1, 9 and 11):** Open center valves are used in single operations where no other operation is performed by the same source of power and where cylinders do not have to be held by pressure. Open center spools are also used to minimize shock in a system. Shock develops when a valve spool is shifted from one position to another across center position. The smoothest possible minimum shock condition is obtained when fluid under pressure is allowed to discharge to tank as the spool passes center condition.

Open center with (A) or (B) ports blocked. A spool of this type is generally used to operate a cylinder. When the spool is centered, a cylinder port is blocked and the cylinder is held in a definite position. In some circuits, flow from the tank port is piped into the pressure port of another valve. This allows the same source of power to operate two different cylinders. This type of arrangement may be used in a system containing a number of operations. However, each operation must be performed in a certain sequence, with only one operation taking place at any one time.

a. **Type “0”** spool is designed with ports (P), (B), (A), and (T) interconnected when the spool is in center position. These ports are momentarily interconnected during spool crossover when the pilot valve solenoid is activated. This permits smooth rapid cycle operation.

b. **Type “1”** spool is designed with ports (P), (A), and (T) interconnected. Port (B) is blocked in center position.

c. **Type “9”** spool is similar to type “0” spool except all ports are partially open in center position.

d. **Type “11”** spool is a type “1” spool reversed in the bore. The type “11” spool interconnects (P), (B), and (T) in center position with (A) blocked.

2. **Closed Center Spools (2, 3, 6, 31 and 33 types):** Closed center spools are used where two or more operations are performed by a single pump or by an accumulator. Closed center valves prevent the loss of fluid from the pump or accumulator when the spool crosses center. The “P” port is blocked as the spool crosses center.

a. **Type “2”** spool blocks ports (P), (A), (B) and (T) from one another in the center position. The ports are momentarily blocked during spool crossover.

b. **Type “3”** spool is designed with ports (A) and (T) interconnected and ports (P) and (B) blocked in the center position.

c. **Type “6”** spool is interconnected at ports (A), (B) and (T). Port (P) is blocked in the center position.

d. **Type “31”** spool is a type “3” spool reversed in the bore. A type “31” spool is interconnected at ports (B) and (T), but blocked at ports (P) and (A) in the center position.

e. **Type “33”** spool provides controlled leakage from port (A) and (B) to port (T). Port (P) is blocked in the center position.

3. **Tandem Spools (4 and 8 types):** Tandem spool valves are used in hydraulic circuits where two or more hydraulic cylinders or motors are controlled from a single source of power. The valve's spool is designed so that in center position, all cylinder connections are blocked and full pump delivery is connected to tank. The tank connection of one valve may be connected to the pressure connection of another valve and both valves operated simultaneously as long as another valve and both valves operated simultaneously as long as the combined pressures developed by the two loads are within the capabilities of the power source.

a. Type “4” spool allows oil to circulate freely from port (P) to port (T) in the center position. Ports (A) and (B) are blocked to the work load.

b. Type “8” spool is designed similar to type “4” spool. Port (P) and (T) are interconnected in the center position. However, ports (A) and (B) are momentarily open during spool crossover.

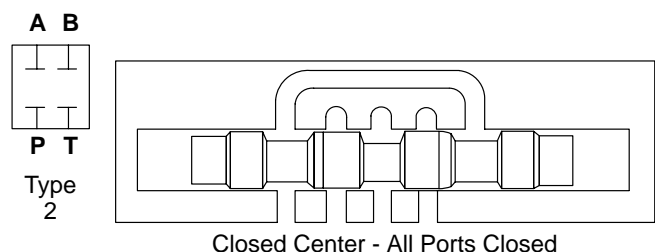
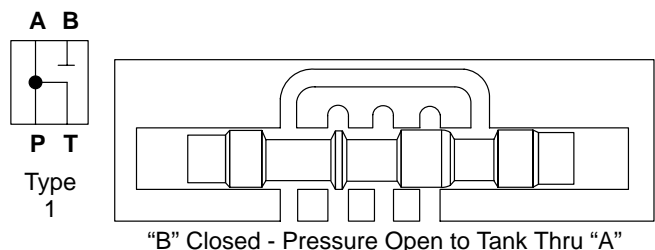
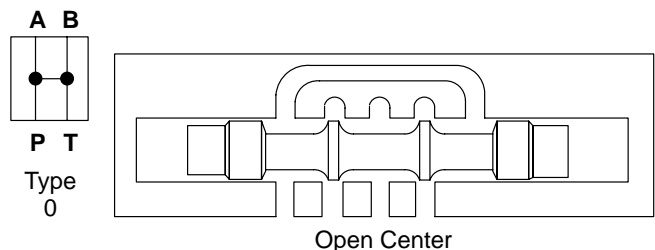

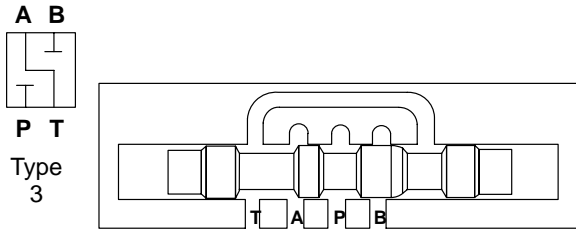

Pressure and "B" Closed - "A" Open to Tank

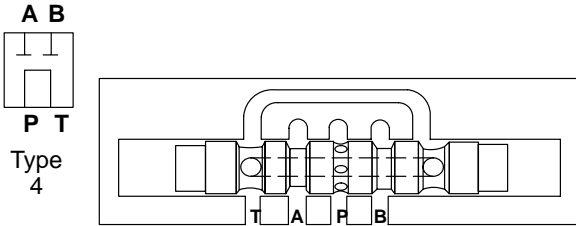

Closed Crossover, Pressure to "T" with "A" & "B" Blocked

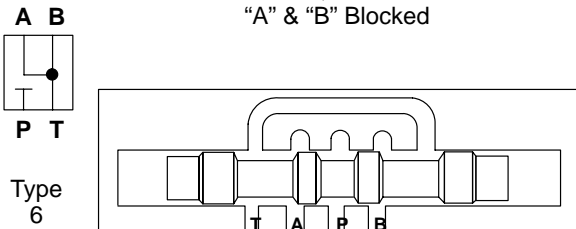

Pressure Closed - "A" & "B" Open to Tank

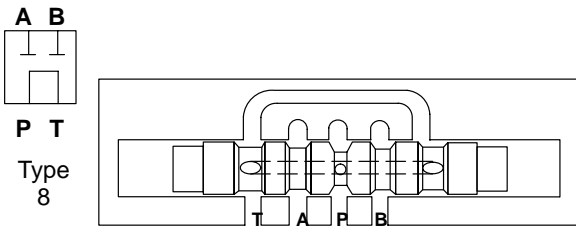

Tandem, Open Crossover, Pressure to "T" with "A" & "B" Blocked

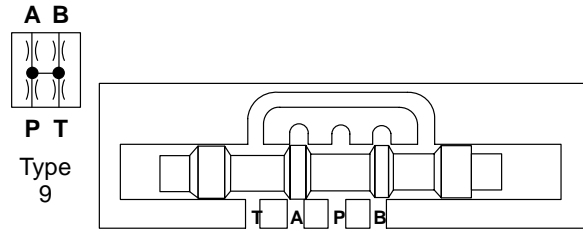

Open Center, Partial - All Ports

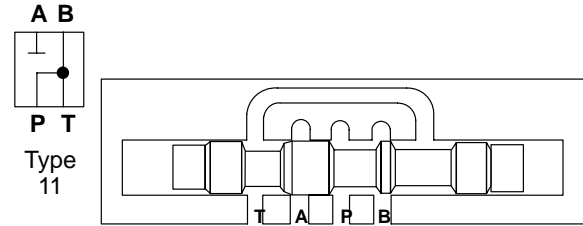

"A" Closed - Pressure Open to Tank thru "B"

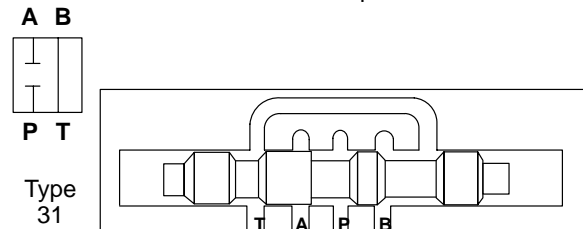

Pressure and "A" Closed - "B" Open to Tank

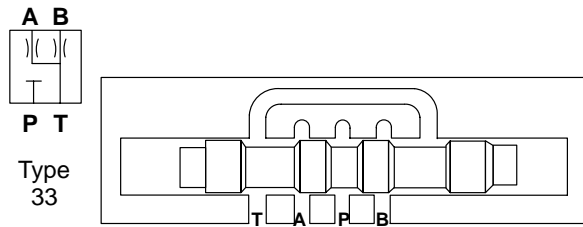

Closed Center - Bleed "A" & "B"

C. Methods of Spool Control, Main Stage

1. Manual Lever (all sizes except the DF*S4-16* size): A manual lever arrangement is available for shifting certain valves. The lever arrangement is connected to a special valve end cover. A spool with an extension protrudes through the cover and is acted upon by the lever. This allows manual positioning of the spool within the body. Large valves require considerable force to move the spool when it is under pressure. For this reason, the two inch valve size is not available with a manual lever control. Examples of valves with the manual lever control are: DG17S4-06*A-50, DG17S4-10*A-50, DG17S4-06*C-50, DG17V-3*-40.

2. Remote Pilot Source: Main stage valves are available for use with a remote source. This means that the valve is shifted from a remote pressure source by other valves in the logic circuit. Examples of valves that use a remote pressure source are: DG3S4-06*C-50, DG3S4-10*C-50 and DG3S4-06*-50.

3. Integral Pilot Valve: The integral pilot type two stage valve is a very common valve used in the field today. Two stage valves allow large volumes of fluid to be switched to and from an actuator with minimum power required for control. Reference Figures 4 through 8, shown in the following section.

D. Main Stage Spool Position

Main stage spools are positioned within the valve by special arrangements. The four basic main stage spool positioning arrangements are: no spring-floating, spring centered, spring offset and pressure centered.

The following paragraphs (1 through 4) describe these arrangements. A fifth function can be obtained by the use of a detent pilot valve. This function is discussed in paragraph five.

1. **No Spring-Floating:** When centering springs are omitted from the main stage spool, the spool is said to be floating. If control pressure is removed, a floating spool can move from its last position under the influence of gravity or tank line pressure. This must be considered during the design of the system. Units with floating type spools have the model code letter omitted. (Example: DG3S4/DG4S4-062-**-51) Figure 4 illustrates floating spool positioning in a two-stage valve.

2. **Spring Centered:** A spring and washer arrangement is used on both ends of the main stage spool in the spring centered configuration. If control pressure is removed from a spring centered spool, the valve will go the center position due to spring force. Two configurations of a two-stage spring centered valve can be obtained, a type "B" and a type "C". If one solenoid is used on a spring centered pilot valve, the model code is identified with the letter "B". When two solenoids are used, the model code is identified with the letter "C". Figure 5 illustrates spool positioning of a two-stage spring centered "C" model (i.e. DG5S4-062C-**-51).

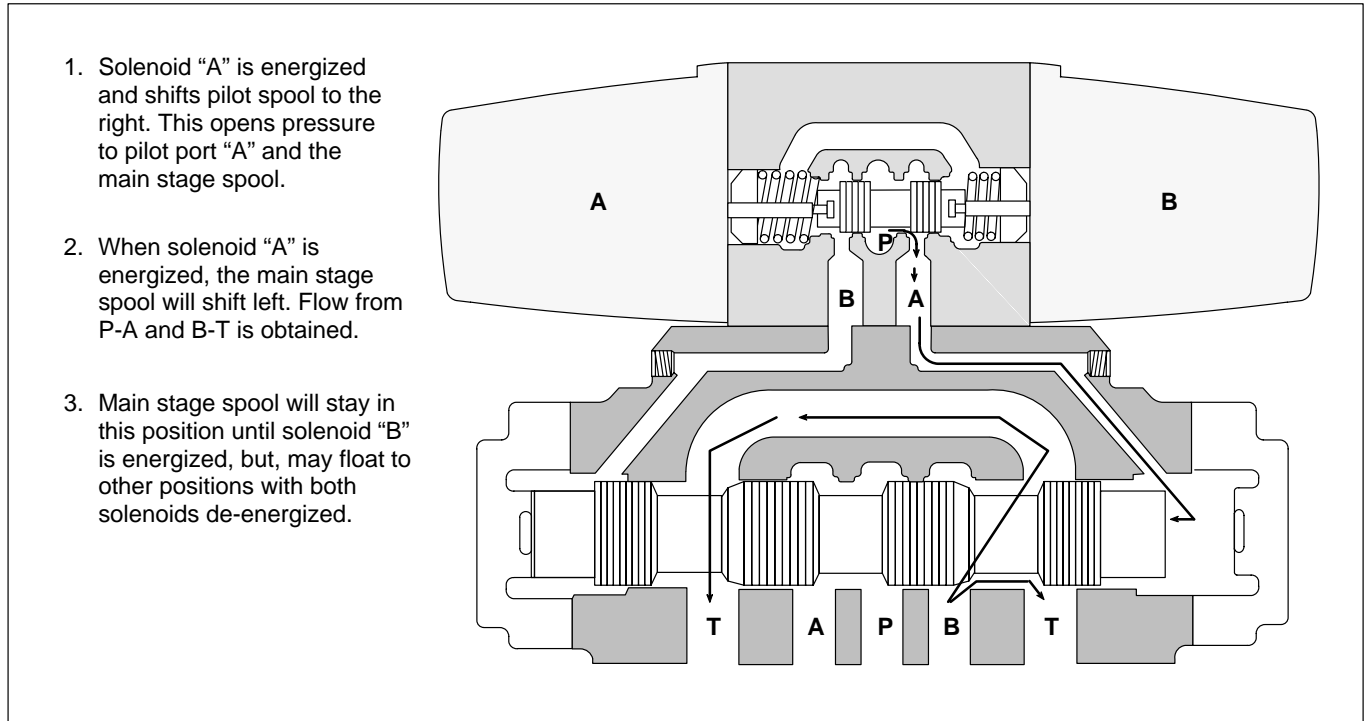

Figure 4. No Springs, Floating Model

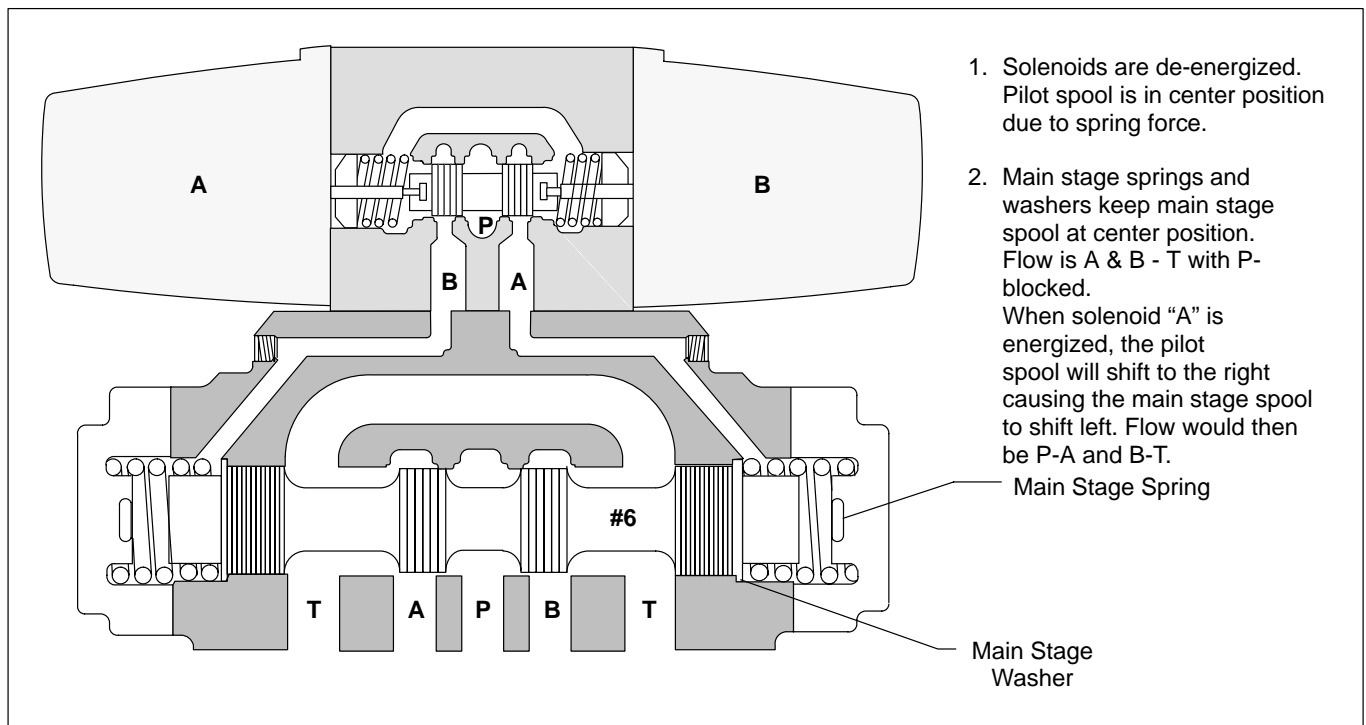

Figure 5. Spring Centered "C" Model

3. Spring Offset: Single stage spring offset models use one spring to return the spool to an offset position. In two-stage models, the spring and washer is removed from the main stage and offset action is obtained from the pilot valve. Offset pilots have a solenoid removed from the spring end of the valve. Spring offset pilots control the main stage when the solenoid is de-energized, through spring action, so long as pilot pressure is available. Spring offset valves have the letter "A" stamped into the nameplate (i.e. DG5S4-062A-**-51). Figure 6 illustrates an offset two-stage valve.

4. Pressure Centered: Pressure centered valves provide a more positive centering arrangement than normal spring centered valves. This is accomplished in the following manner:

Assume both pilot valve solenoids are de-energized and the main stage spool is positioned to the left (see Figure 7). Pilot pressure is applied to both ends of the main stage from the number seven (7) pilot spool. The sleeve moves to the right under the influence of the spring and pilot pressure until the piston shoulder is contacted. Since the sleeve and piston areas are greater than the total spool area at the right hand end of the valve, the sleeve continues to move to the right carrying the piston with it until it contacts the valve body (center position).

Assume the main stage spool was positioned to the right with both pilot valve solenoids de-energized, pilot pressure is applied to the sleeve and piston areas on the left side but the sleeve is bottomed against the valve body at this time. Only the piston area applies force to the left end of the spool. Since the spool land area at the right side is greater than the piston area, the spool will be forced to the left until the piston shoulder butts against the sleeve (center position).

If pilot pressure falls below 150 psig, the centering springs will cause the spool to center within the valve body.

Pressure centered valves are not available with integral check valves. (Refer to Section V, Internal Valve Functions, for integral check valve information.) Pressure centered models have the letter "D" stamped into the unit nameplate (i.e. DG5S4-062D-**-51). Figure 7 illustrates spool/spring arrangement on pressure centered models.

NOTE

A fifth condition of the main stage spool can be obtained through use of a detent pilot stage. Refer to the following paragraph.

5. Detent Valve Operation: Detent valve operation can be achieved by installing a detent into the pilot valve. A detent is assembled on one or both ends of the pilot spool depending on the type of pilot valve used. When a pilot valve solenoid is de-energized, the detent holds the pilot spool in its last position and the main stage spool remains in its last position.



CAUTION

If pilot pressure fails or falls below the minimum requirement of 75 PSIG, the main stage spool will shift to center position even though the pilot valve remains in the last detent position. For this reason, flow conditions in center or neutral position must be selected with care.

Detent models are indicated by the letter "N" stamped into the unit nameplate (i.e. DG5S4-062N-**-51). Figure 8 illustrates the spool/spring arrangement on detent models.

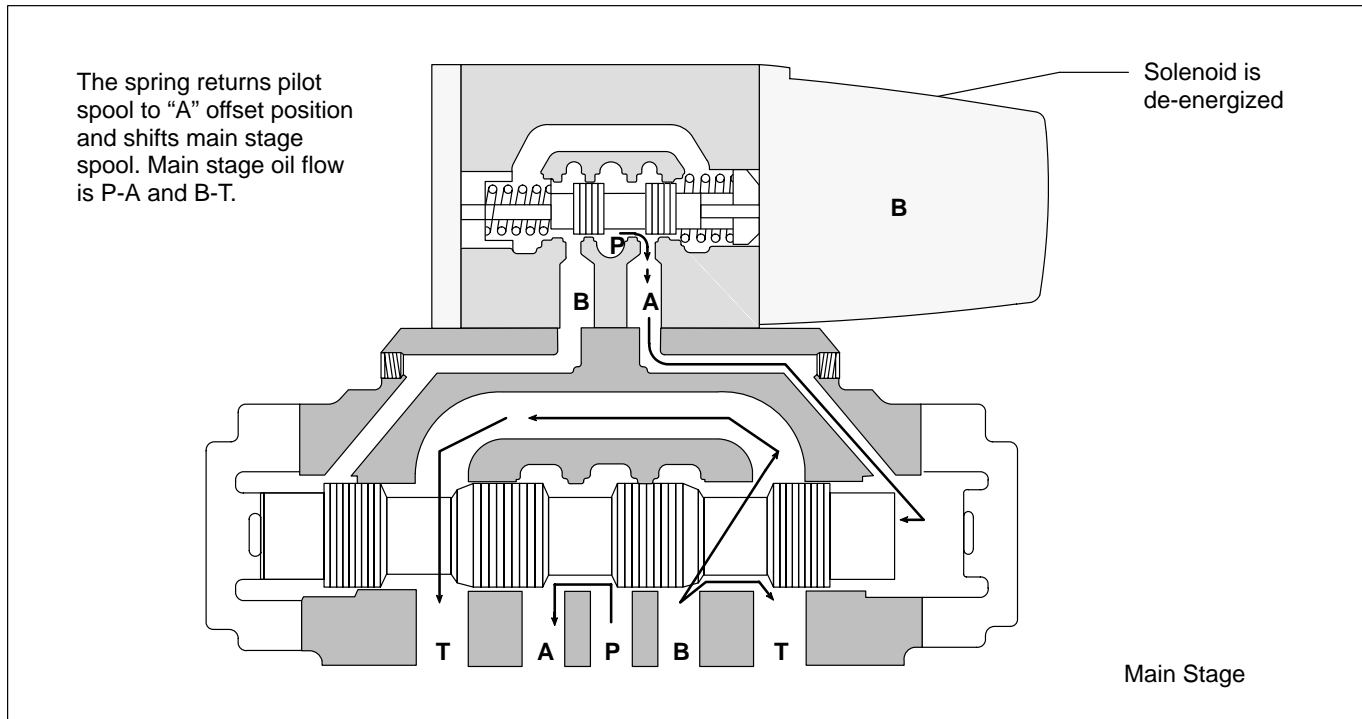

Figure 6. Spring Offset "A" Model

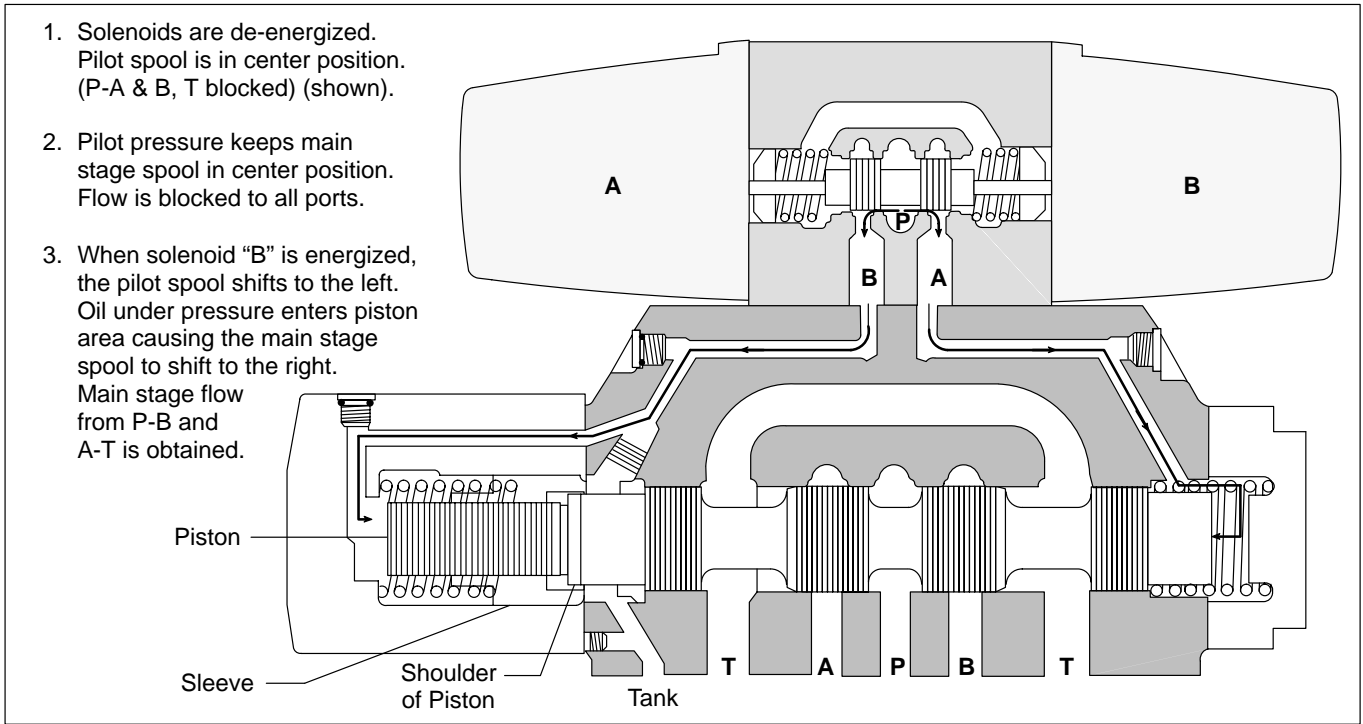

Figure 7. Pressure Centered "D" Model

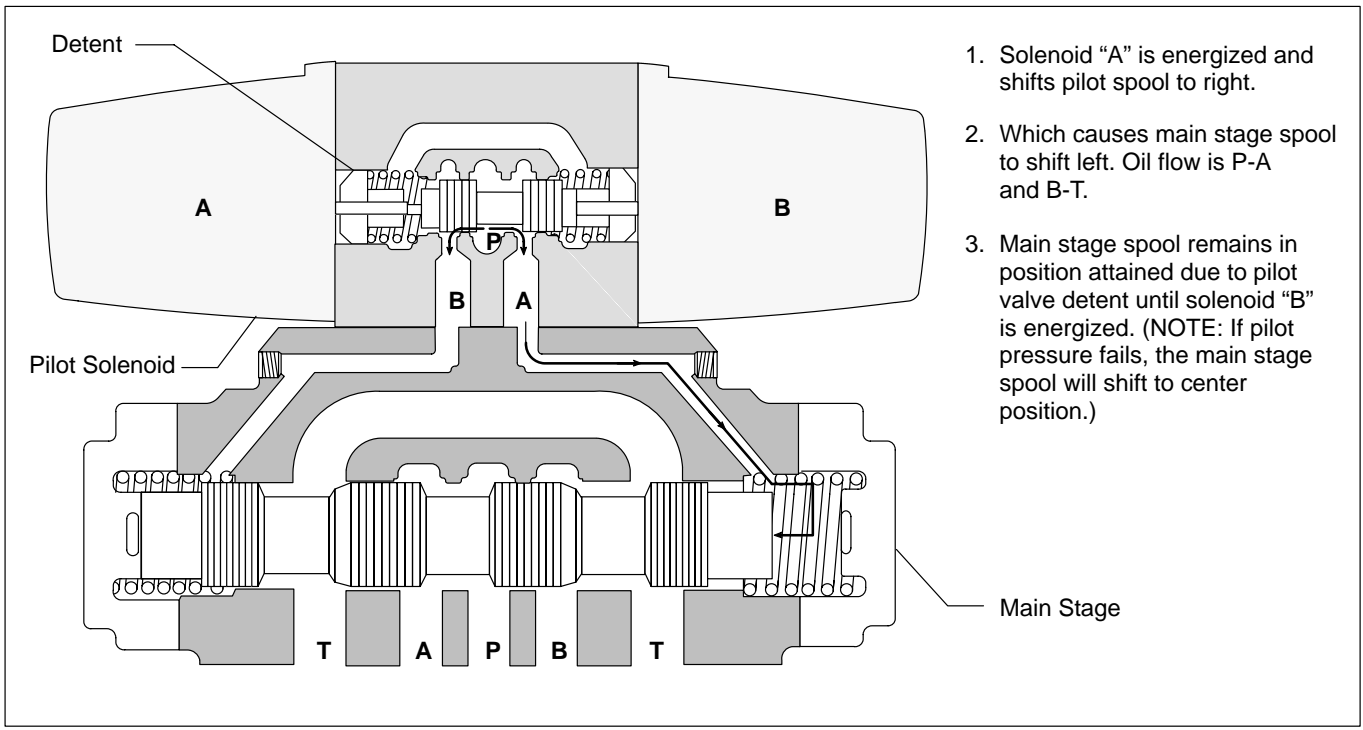

Figure 8. Detented "N" Model

E. Optional Features (Main Stage)

Control of the main stage spool can be modified with certain optional features. The most common features are discussed in the following paragraphs.

1. Stroke Limiter Adjustment: Main stage spool travel can be limited by using stroke adjust covers. Stroke adjust covers may be used on one or both ends of the main stage section. When the stroke is limited, maximum flow through the valve is reduced (assuming the same inlet pressure). This slows the actuator movement.

To limit the spool travel, loosen the jam nut and turn adjusting screw clockwise. Figures 9 and 10c illustrate the stroke limiter feature.

2. Pilot Choke Option: A pilot choke increases the amount of time it takes to shift the main stage spool from one position to another. Increasing shift time lowers the possibility of developing large flow transients in the circuit. A pilot choke is designed to allow free flow to one end of the main stage spool but restricts flow out of the opposite end. The rate of spool travel, in either direction, can be slowed by loosening a locknut and turning an adjusting screw

clockwise. To increase the rate of spool travel, turn the adjusting screws counterclockwise. When a pilot choke is used, pilot pressure should be taken from a constant pressure source. The pilot choke is mounted between the pilot valve and the main stage sections. See Figures 10a, 10b and 10c for pilot choke details.

3. Fast Response Option: Some applications require the main stage spool to shift at a faster than normal rate. For such applications, the fast response option is used. This option requires the removal of an orifice plug within the main stage body. When the orifice plug is removed, larger volumes of fluid will enter the pilot valve section. When the pilot valve shifts, the main stage spool responds at a faster rate. However, this also generates transients that increase system shock. For this reason, the fast response option is not recommended when pilot pressures exceed 140 bar (2000 psi). Fast response models have the letter "X" stamped into the unit nameplate (i.e. DG5S4-062**X-51). Table 3 compares standard shift times to the fast response option. Figure 23a and b through 27a and b show the location of the orifice plugs that must be removed for the fast response option.

Typical Shift Times in Seconds for AC Models						
Pilot Pressure (psi)	Standard			Fast Response		
	Center to "A" or "B"			Center to "A" or "B"		
	Model 06	Model H06	Model 100	Model 06	Model H06	Model 100
500	.100	.130	.135	.045	.070	.090
1000	.060	.085	.090	.035	.060	.060
2000	.050	.070	.070	.035	.060	.050
3000	.050	.070	.055	.035	.060	.050

All spring centered models require approximately .08 (06), .15 (H06), .19 (100) of a second to center from either side. DC solenoid shift times will be approximately three or four times the above AC values.

Table 3. DG5 Shift Times (AC Solenoids)

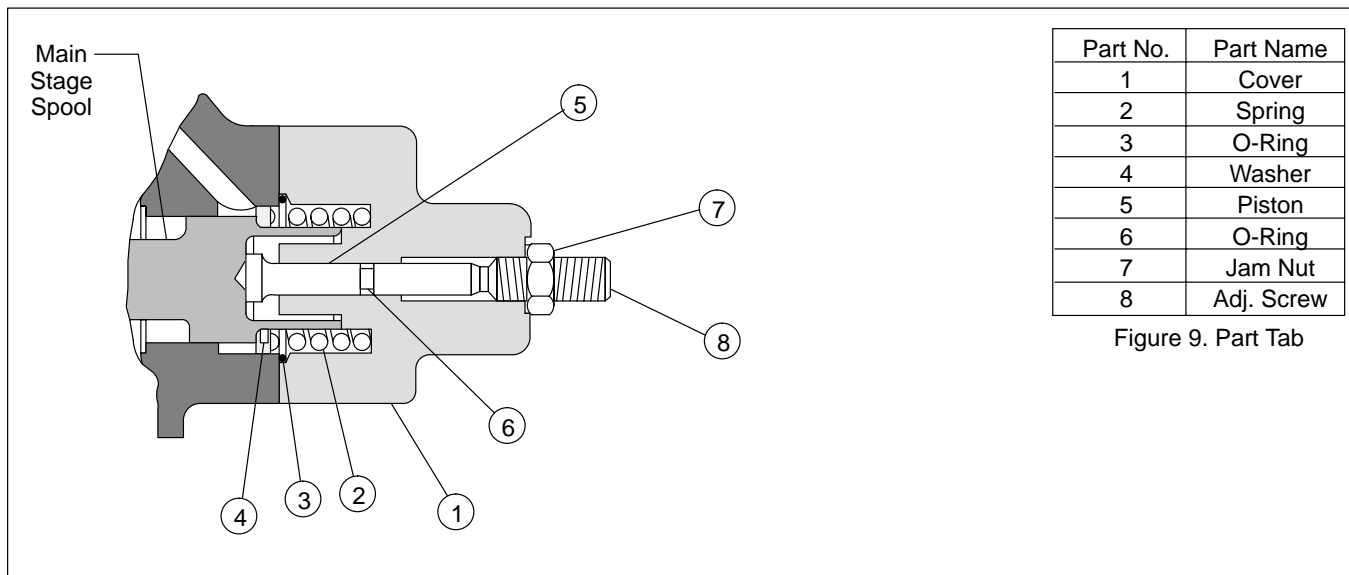
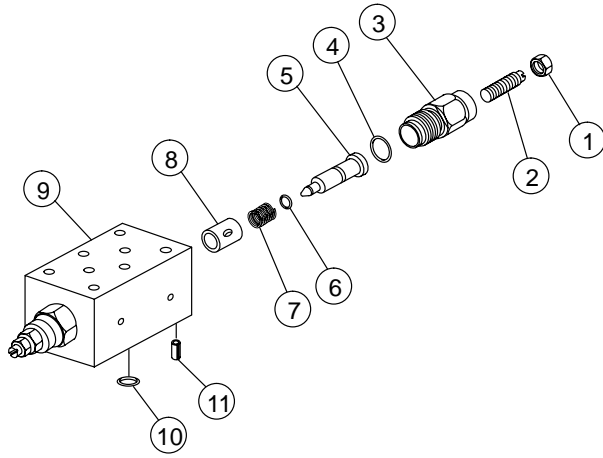

Figure 9. Stroke Adjuster Feature

DGMFN-3-21



Part No.	Part Name	Qty.
1	Screw	2
2	Nut	2
3	Needle Housing	2
4	O-Ring	2
5	Needle	2
6	O-Ring	2
7	Spring	2
8	Poppet	2
9	Body	1
10	O-Ring	4
11	Roll Pin	1

Figure 10a. Part Tab

Figure 10a. Pilot Choke - DGMFN-01-20 (Use with DG4S4-01 Series)

DGMFN-01-20

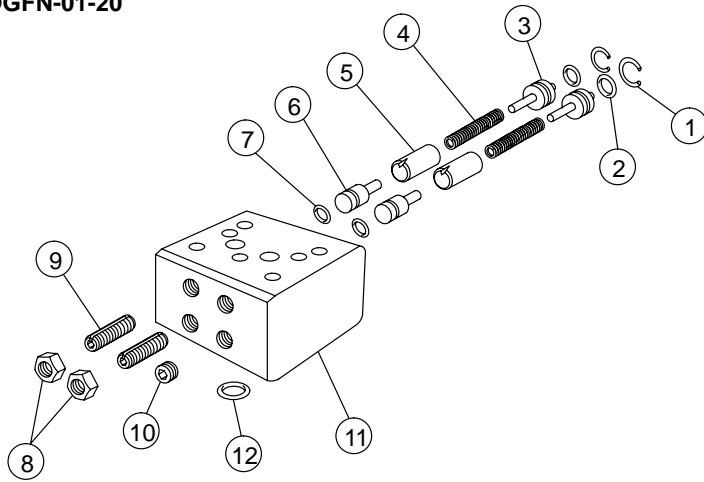

Part No.	Part Name	Qty.
1	Retaining Ring	2
2	Plug	2
3	O-Ring	2
4	Spring	2
5	Check Valve	2
6	Stop	2
7	O-Ring	2
8	Lock Nut	2
9	Adj. Screw	2
10	Plug	2
11	Body	1
12	O-Ring	5

Figure 10b. Part Tab

Figure 10b. Pilot Choke - DGMFN-01-20 (Use with DG4S4-01 Series)

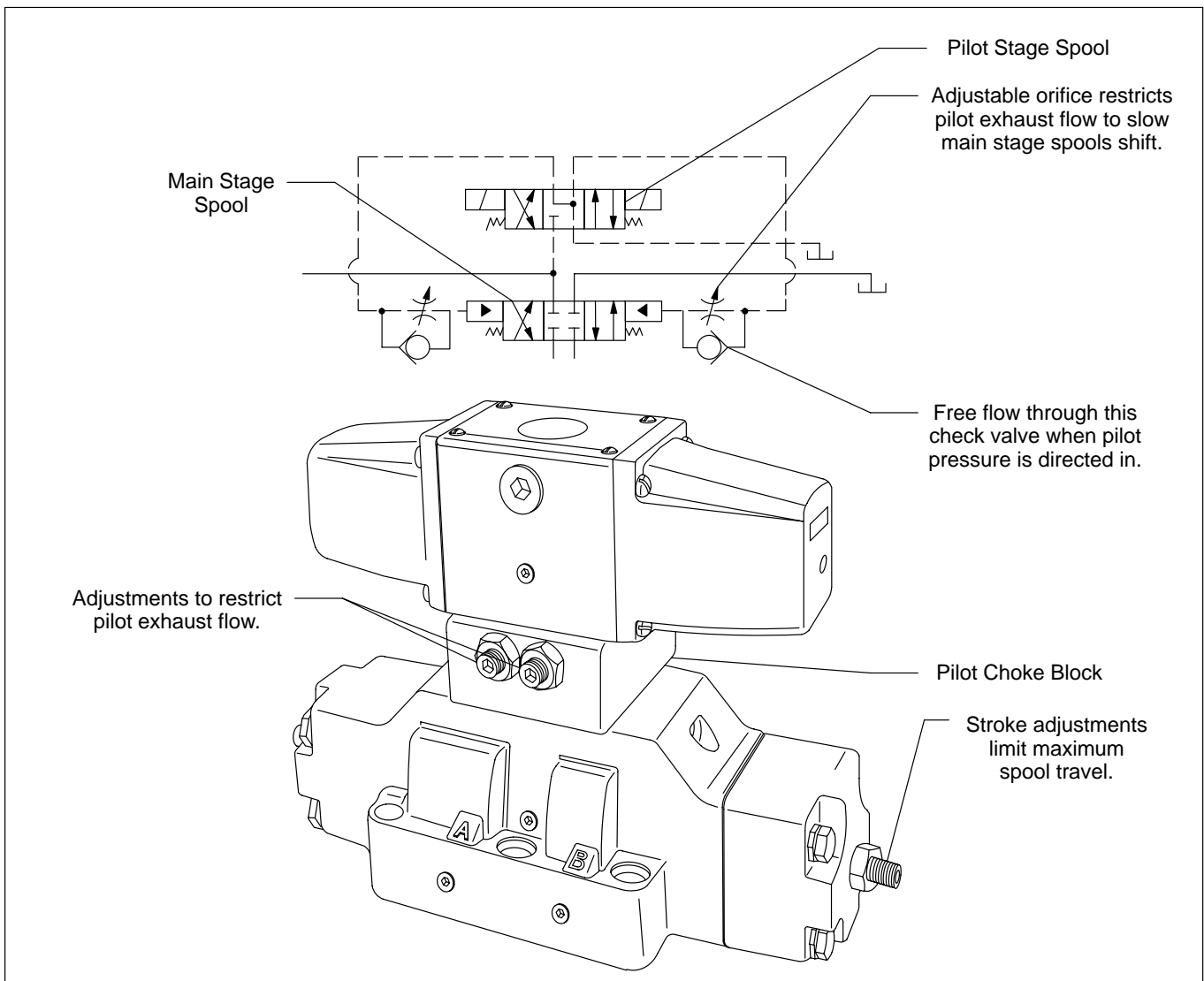

Figure 10c. DG5S4 with Pilot Choke & Stroke Limiter Options

Section IV – Pilot Valve Section

A. Spool Type - Pilot Valve Section

To maintain proper control, closed center pilot spools are normally used on two stage valves. In most cases, a number “6” type pilot spool is used.

When a type “4” or “8” main stage spool is used, the number “6” pilot spool is identified as number “68”. This spool combination requires the pilot valve to be assembled left hand on single solenoid models. Refer to installation drawing (Table 1) for more information.

The number “7” pilot spool is identified as a number “78” when a “4” or “8” type main stage spool is used on pressure centered “D” models.

B. Spool Positioning - Pilot Valve Section

Pilot spools are positioned within the valve by special spool arrangements. The three basic pilot valve spool arrangements are spring centered, spring offset and detents. The following paragraphs (1 through 3) describe pilot spool arrangements.

1. **Spring Centered:** A spring and washer are installed at each end of the pilot valve spool. The spring moves the spool until the washer contacts the end of the valve body. In the de-energized condition of the pilot valve, the spool is held in center position within the body by the springs and washers.

2. **Spring Offset:** Spring offset models use one spring and washer to return the pilot valve spool to an offset position. In this model, a solenoid is completely removed from the spring end of the pilot valve. Solenoid operating power is reduced by the sacrifice of the center spool position.

3. **Detents:** A detent mechanism is installed on one or both ends of the pilot valve spool. Detent valve solenoids can be momentarily energized to the correct position and then power may be removed from the solenoid. This reduces the input control power below that of an offset model. The detent(s) hold the pilot spool in the last position attained until the opposite solenoid is energized. As in the offset valve, solenoid power is reduced by the sacrifice of the center spool position.

C. Methods of Control - Pilot Valve

The following pilot control methods are available for pilot and spool position.

Control	Model Codes
Manual Lever/Roller	DG17/20V-3
Remote Pilot	DG3V-3
Air Type Solenoid	DG18V-3, DG18S4-01
Electrical Solenoid	DG4S4-01, DG4S4-01-W, W, DG4V-3

1. **Manual Lever/Roller:** A manual lever is available for shifting certain valves. The lever arrangement is connected to a special valve end cover. A spool with an extension protrudes through the cover and is acted upon by the lever. This allows manual positioning of the pilot valve spool within the body. In some valves a roller is used instead of a lever to actuate the pilot spool.

2. **Remote Pilot:** Pilot valves, such as a DG3V-3-40, are available for use with a remote pilot source. This means that a valve can be shifted from a remote pressure source by other valves in the logic circuit. Refer to service parts drawing I-3871-S.

3. **Air Type Solenoids:** Air operated pilot valves are actuated with air pressure through a connection plate.

A DG18V-3-C-40 or DG18S-01-L-52 air type valve can be used to control the main stage of a DG19S4-062C-**-51 two stage unit (see Figure 11a). When air pressure (50 psi minimum) enters the pilot valve air chamber, the piston moves the pilot spool. This allows control flow to enter the main stage section (see Figure 11b).

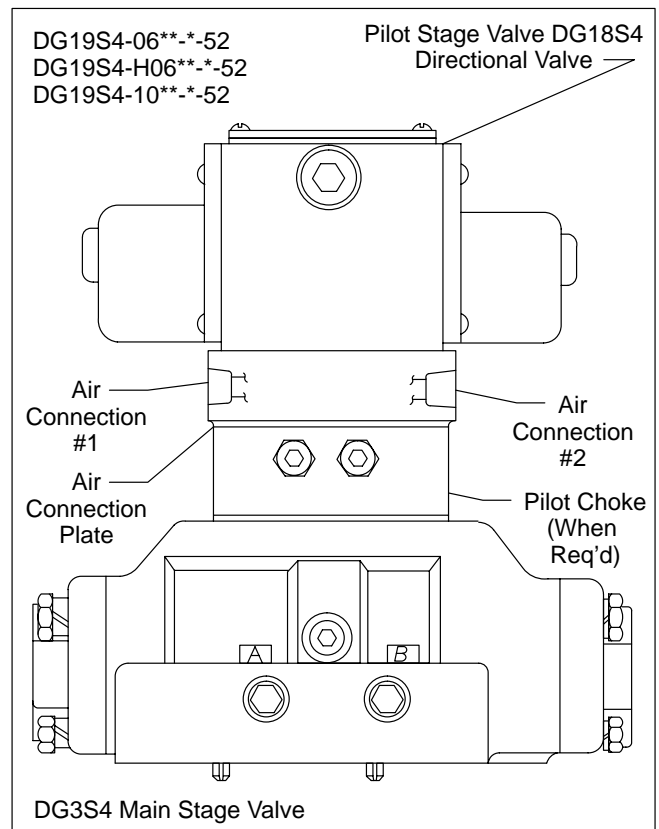

11a. DG19S4-**-52 Two Stage Valve

The DG18S4-06 and DG18S-8 air operated valves do not use a pilot stage but are shifted directly by large air pistons located at each end of the spool. The air pistons operate similarly to those of the DG18S4-01* pilot shown in Figure 11b. A connection plate is required to feed air to the pistons.

4. **Electrical Solenoid Pilot Operation:** Electrical solenoids are attached to the pilot valve body. Internal push pins connect the solenoid to the pilot spool. When the magnetic field of solenoid "B" is energized, the solenoid armature moves the push pin and shifts the pilot spool towards solenoid "A" (see Figure 12a). When solenoid "A" is energized, the pilot spool shifts toward solenoid "B" (see Figure 12b). When both solenoids are de-energized, the pilot spool shifts to center position (see Figure 12c).

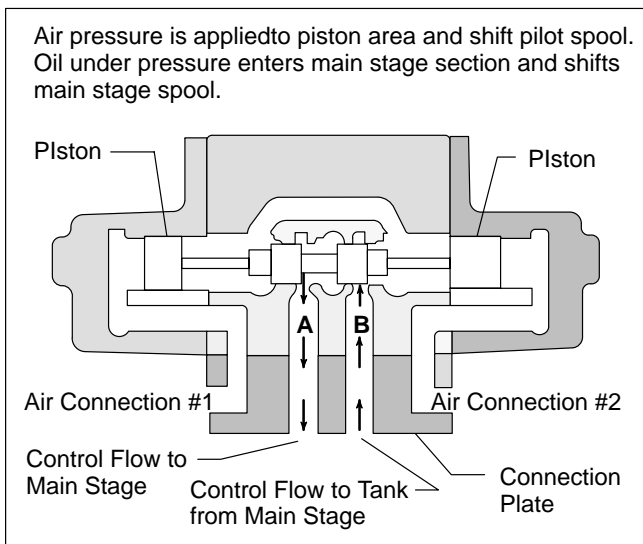

Figure 11b. DG18S4-**-52 Air Operated Pilot Valve



CAUTION

DO NOT energize both (AC) solenoids simultaneously. Sustained operation with both solenoids energized will cause excessive current in the coil and accelerates burnout.

a. **Electrical Solenoid Types Available:** Three basic types of electrical solenoids exist: Wet armature, air gap and oil immersed. The unit nameplate identifies the type of solenoid being used. See the model code in Table 2. If a 50 or 51 design two stage valve is equipped with a DG4V-3 pilot valve, the letter "M" is stamped into the nameplate (i.e. DG5S4-062*-M-51). The letter "M" indicates an adapter plate is used to provide the necessary DG4V-3 pilot valve interface requirements.

b. **Wet Armature Type Solenoids:** Wet armature solenoids are standard on DG4V-3 and DG4S4-01-W/W3 pilot valves only. Wet armature solenoids have many design advantages over other types of solenoids. Some advantages include cooler operation, static sealing arrangements, immunity to moisture and greater burn-out resistance.

DG4V-3 and DG4S4-01*-W wet armature solenoids are not serviced with individual parts. Service is provided by replacing the entire core tube subassembly. Parts can be removed, cleaned and seals replaced on "W3" type solenoids.

c. **Air Gap Solenoids:** DG4S4-01 pilot valves are usually equipped with air gap solenoids. Air gap solenoids are isolated from system fluid and can be removed and replaced without disturbing the system. A push pin and sliding seal arrangement couple the solenoid to the valve spool (see Figure 13c).

d. **Oil Immersed Solenoids** (early type wet armature solenoid - no longer recommended for new equipment): DG4S4-01 pilot valves may be equipped with oil immersed solenoids. This solenoid provides a certain amount of dampening of the solenoid parts and extends unit life. The standard wet armature solenoid provides this same feature. Oil immersed solenoids are not repairable except by the manufacturer and are not directly interchangeable with air gap or wet armature type valves. Oil immersed type solenoids have the letter "H" stamped into the nameplate.

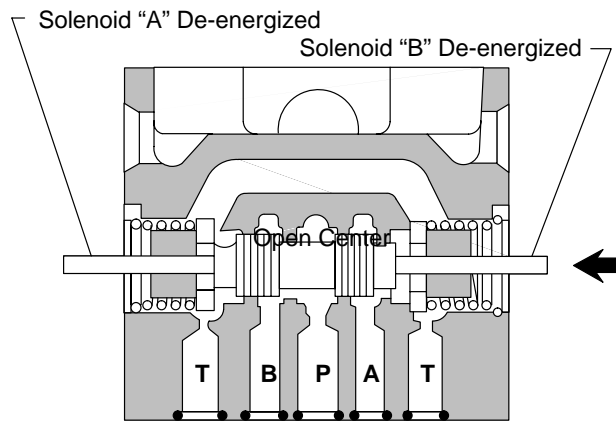

12a. Flow Conditions Pressure to "B" - "A" to Tank

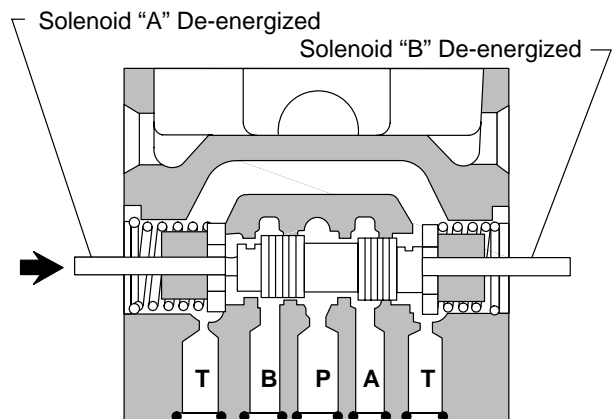

12b. Flow Conditions Pressure to "A" - "B" to Tank

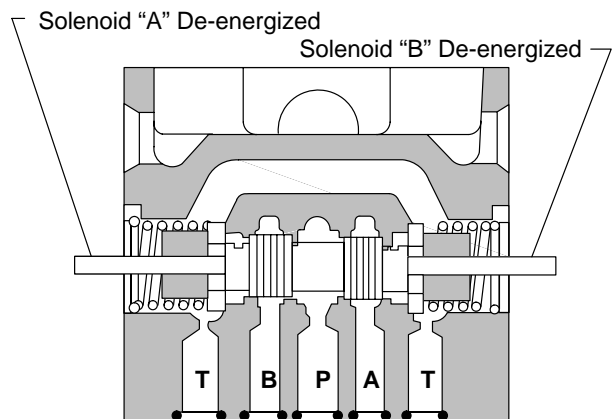

12c. Flow Conditions Blocked (Center Condition #2 Spool)

e. **Electrical Solenoid Voltage Requirement:** Electrical solenoids are available in various AC and DC voltage ranges. The standard voltage and frequency range is 115 VAC, 60 Hz. Refer to parts and service drawings for units with non-standard voltage ranges. Fifty (-50) and fifty-one (-51) design units have the voltage and frequency range stamped into the nameplate if other than standard. Ten (-10), twenty (-20) and fifty-three (-53) design units use an identification letter for the coil voltage and frequency.

f. **Electrical Solenoid Ground Connections and Wiring Housing:** An electrical wiring housing with a 1/2 inch NPTF thread connection is available on DG4V-3 and DG4S4-01 pilot valves. The wiring housing can be rotated

180° from the position shown in Figure 13a. Wire grounding screws are provided for convenience.

g. **Manual Override:** Each solenoid (electrical or air type) has a manual override plunger to shift the pilot spool. This feature allows a technician to shift the pilot spool when electricity or air pressure is not available. Refer to Figures 13a, 13b or 13c. To operate the manual override feature, obtain a small rod and push in on the plunger.

5. **Accessories for Electrical Type Solenoids:** The model code (Table 2) indicates the type of accessories used on directional valves. Obtain a parts and service drawing for your particular model (see Table 1). Most accessories pertain to the pilot section. The most common types of accessories are discussed in the following paragraphs (a through f).

a. **Hazardous Location Solenoids:** This type of solenoid is used at locations where added protection from electrical shortage failure is mandatory. The solenoid housing is designed to completely enclose all wiring connections to the valve. Hazardous location valves are underwriters approved Class 1, Group D or Class 2, Group E-F-G, for 115 and 230 volts, 60 Hz service.

Valves for mining applications are built to the Bureau of Mines schedule 2G-File X/P 837-2 and are available in all standard voltages. Refer to parts drawing (Table 1) for further information.

b. **Monitor (Limit) Switch Feature:** The monitor switch feature can be incorporated into a basic spring offset directional valve. The switch monitors valve spool position and can be wired into control circuits. This permits electrical interlocking of various hydraulic controlled motions without resorting to external mechanical arrangements. The monitor switch is a single pole, double throw contact arrangement with "A"- normally closed and "B"- normally open. Switch ratings are noted on installation drawing (Table 1). The monitor switch housing does not provide a manual plunger for operation of the switch or valve.

c. **Insta-Plug Connectors:** Pilot valves can be supplied with electrical connectors called insta-plugs. These connectors allow quick disconnect of electrical power from the valve. The following data pertains to the insta-plug feature:

PA - A prefix of PA in the model code indicates the male plug section of the insta-plug feature is included on the valve.

PB - A prefix of PB in the model code indicates both the male plug and female receptacle are included with the valve. The insta-plug feature is available on both the DG4V-3 and DG4S4-01 series directional valve.

WIRING NOTE

Connect white wires to "A" solenoid and black wires to the "B" solenoid. Refer to parts drawing (Table 1) for additional data.

d. **Brad Harrison Connectors:** Brad Harrison connectors thread into the 1/2 NPTF opening in the wiring housing of a DG4V-3 or a DG4S4-01 directional valve.

PA3 - A prefix of PA3 in the model code indicates the three pin male connector is included with the valve.

PA5 - A prefix of PA5 in the model code indicates the five pin male connector is included with the valve.

Female Brad Harrison connectors are not available from Vickers and must be supplied by the customer.

e. **Solenoid Indicator Lights:** Solenoid indicator lights are available for installation on both the DG4V-3 and DG4S4-01 series directional valves. Indicator lights are connected across the solenoids and will light when voltage is present at the solenoid. This gives an indication to the technician which solenoid is energized and aids in troubleshooting a system. Refer to the appropriate parts drawing for additional information.

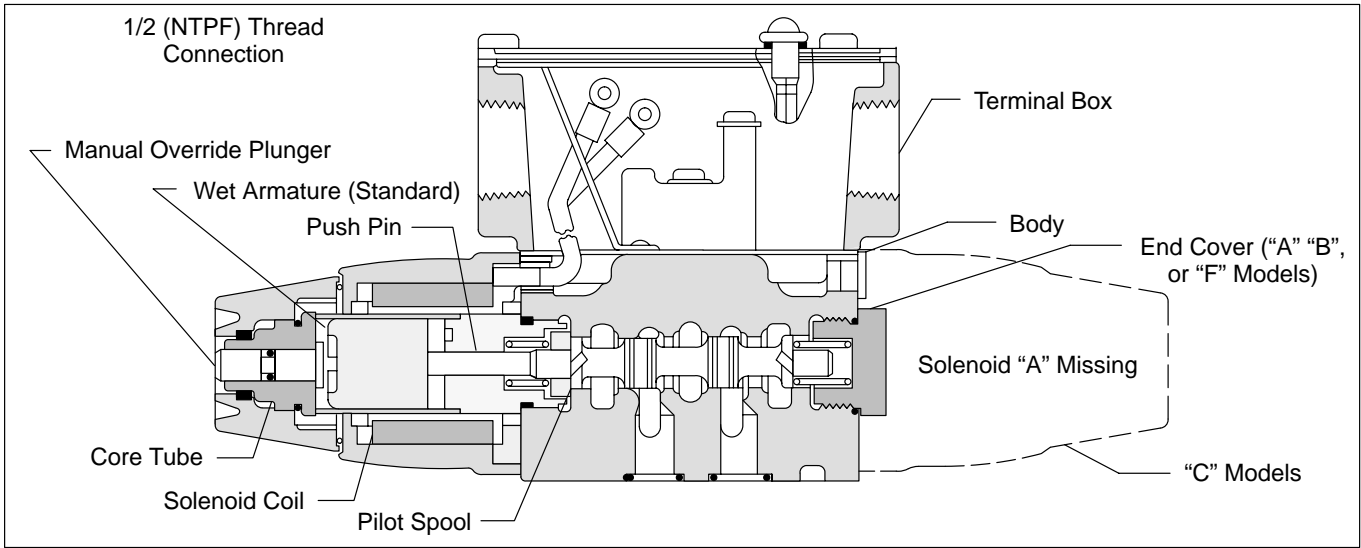

Figure 13a. DG4V-3-40 Pilot Valve, Sectional View

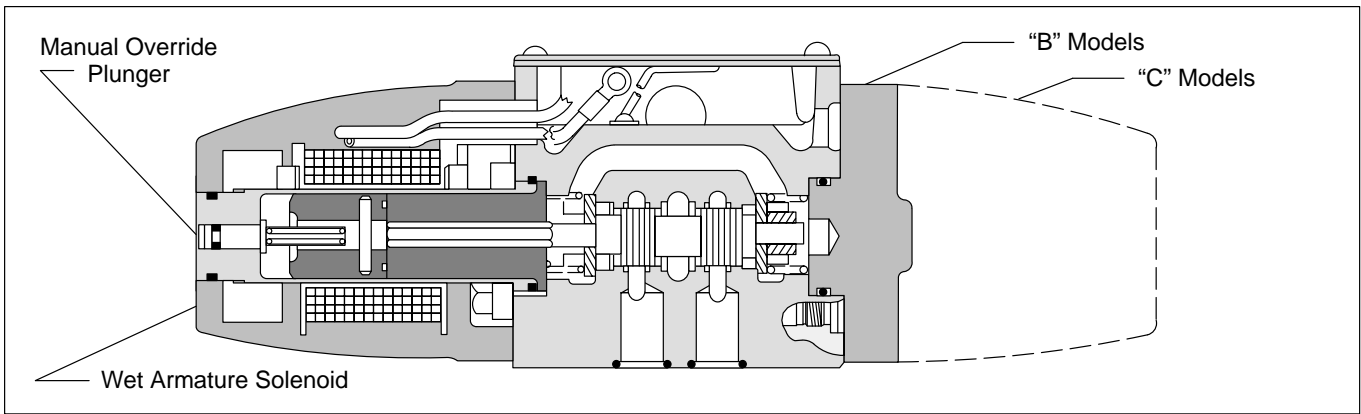

Figure 13b. DG4S4-W-50 Pilot Valve, Sectional View

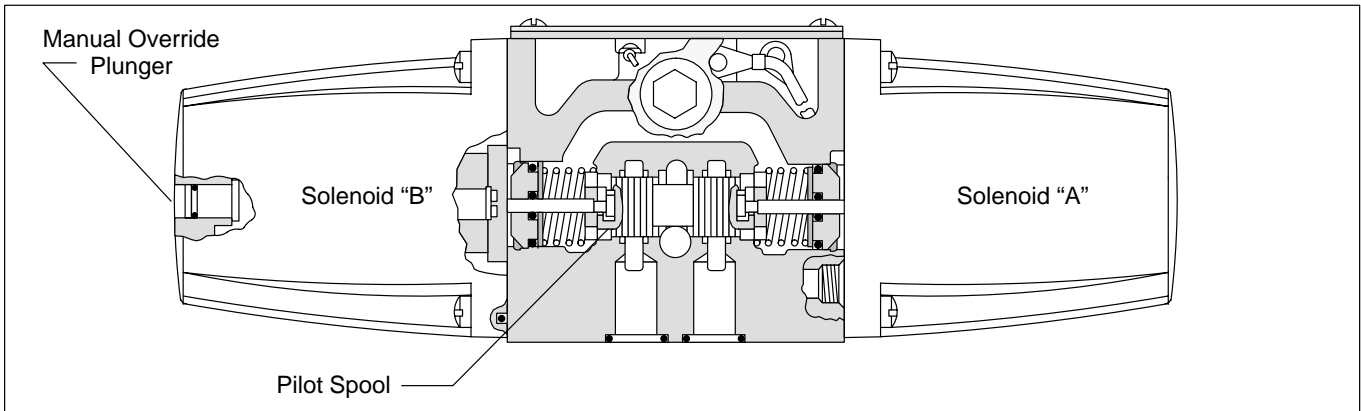

Figure 13c. DG4S4-01-50 Pilot Valve, Sectional View

Section V – Internal Valve Functions

A. General

To insure the proper application of a two stage valve, pilot pressure, pilot drain and integral check valve options must be considered. The following paragraphs (B through D) discuss these options.

B. Pilot Pressure

1. **Internal Pilot Pressure (Standard):** Internal pilot pressure can be obtained in two ways and must be tailored for the application. Models with closed center type spools automatically provide internal pilot pressure. Models that use open center type spools require a check valve in the pressure (P) port to maintain minimum pilot pressure. In most cases, maximum internal pilot pressure is rated to 210 bar maximum (3000 psi). Minimum pilot pressure ratings are noted in the installation drawings (see Table 1).

2. **External Pilot Pressure:** When pilot pressure from a separate source is used, it must be connected to the “X” port (external pilot pressure connection). Models that use external pilot pressure do not require a check valve at the pressure port. External pilot pressure models are identified with the letter “E” stamped into the unit nameplate (i.e. DG5S4-062***E-51). Maximum external pilot pressure is also rated at 210 bar (3000 psi).

3. **Pilot Pressure Conversions:** If it is necessary to convert your unit from external pilot pressure to internal pilot pressure or vice versa, internal plug(s) must be removed or added to the main stage body. See the figures noted in Table 8 for internal plug locations.

4. **Pressure Centered “D” Models (H06 & -10 Series only):** A pre-set pilot pressure can be obtained in these models. Refer to the model code in Table 2 for pressure settings. Pilot pressure can be increased or decreased by simply changing internal plugs in the main stage body. Refer to plug table in parts drawing for part numbers and see the figure noted in Table 8 for internal plug locations.

C. Pilot Valve Drains

1. **Internal Drain:** Internal drain models are used when pressure surges in the tank line are small and CAN NOT overcome pilot pressure.

To shift a pilot spool, pilot pressure must always exceed tank pressure by a minimum amount. Figure 14 is an example showing pilot pressure vs. tank pressure. Refer to the unit installation drawing for minimum pressure ratings. Internal pilot drain models have the letter “T” stamped on the unit nameplate (i.e. DG5S4-062-***t-51).

NOTE

A 150 psig ΔP must always be maintained to shift closed center pilot spools. A 75 psig ΔP must always be maintained to shift open center pilot spools.

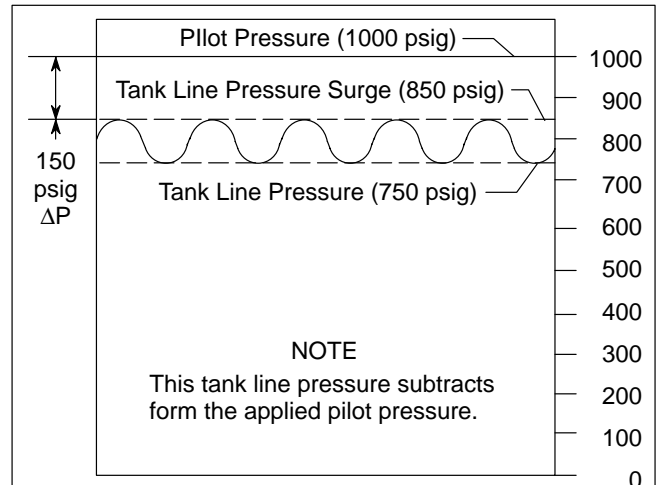

Figure 14. Pilot Valve - Internal Drain

2. **External Drain (Standard):** External drain models are recommended if pressure surges in the tank line CAN overcome pilot pressure. Drain connection “Y” is used for externally drained models. Pressure centered “D” models use two drain connections “Y” and “W”. All external drain connections MUST be piped directly to tank through surge free lines. Refer to the installation drawing (Table 1) for further information.

3. **Drain Conversions:** If it is necessary to convert your unit from external drain to internal drain or vice versa, an internal “T” plug must be added or removed to the main body section. Figures 23c, 24c, 25c, 26c, and 27c show internal “T” plug locations on various models.

D. Integral Check Valves

Check valves are located within the pressure port of the main stage section. The purpose of the check valve is to develop back pressure, at the pressure port, when open center or tandem main stage spools are used. Back pressure is necessary to maintain internal pilot pressure when the main stage spool shifts to open center position. Table 4 indicates when an integral check valve is required.

Pilot Pressure Source	Integral Check Valve Req'd	Main Stage Spool Type
Internal	Yes	0, 1, 4, 8, 9, 11
	No	2, 3, 6, 31, 33
External	No	All Spools

Table 4. Integral Check Valve Circuit Requirements

Integral check valves are applicable at various cracking pressure ranges. Refer to the model code in Table 2 for check valve pressure ranges. The unit nameplate identifies which check valve is used (i.e. DG5S4-062-***K*-51). Refer to installation drawing (Table 1) for additional check valve information.

NOTE

As an alternate to the integral check valve, a 50/75 psi check valve can be installed in the tank line of the valve to obtain pilot pressure.

Section VI – Installation

A. Installation Drawings

The installation drawings listed in Table 1 show installation dimensions, port locations and operating parameters. Manifold, subplate and bolt kit information is also included.

NOTE

Detent valves must be installed with the valve spool in the horizontal position for good machine reliability. The mounting position of spring offset and spring centered models is unrestricted.

NOTE

Make sure the “Y” drain port is piped directly to the tank. Back pressure cannot be tolerated at this valve port.



CAUTION

On solenoid operated directional valves make sure an electrical ground is connected to the valve. This prevents the possibility of a shock hazard if a coil develops a short circuit to the frame.

B. Fluids and Seals

Standard seals (Nitrile) can be used with petroleum, water-glycols, and water-oil emulsion type fluids.

F1 seals (Butyl, EPR) must be used for alkyl phosphate-ester base fluids and aircraft type fire-resistant fluids. F1 seals cannot be used with petroleum or phosphate ester-hydrocarbon blends.

F3 seals (Viton*) can be used with all commonly used industrial hydraulic fluids. Viton* is compatible with petroleum, water-base and synthetic fire-resistant fluids.

*Trademark of Dupont DeNemours Co., Inc.

The following table summarizes the compatibilities of the most common phosphate ester fluids.

Fluid Type	F1	F3
Skydrol	Yes	No
Pydraul 10-E	Yes	No
Pydraul 29-E-L-T, 50-E, 65-E, 115-E	Yes	Yes
Pydraul 230-C, 312-C, & 540-C	No	Yes
Fyrquel & Fyrlube	Yes	Yes
Fyrtek	No	Yes
Houghto Safe 1000 Series	Yes	Yes

C. Piping and Tubing

1. All pipes and tubing must be thoroughly cleaned before installation. Recommended cleaning methods are sandblasting, wire brushing and pickling. Refer to instruction sheet 1221-S for pickling instructions.

2. To minimize flow resistance and the possibility of external leakage, use only the necessary fittings and connections required for proper installation.

3. The number of bends in tubing should be kept to a minimum to prevent excessive turbulence and friction of fluid flow. Tubing must not be bent too sharply. The recommended radius for tube bends is three times the inside diameter.

D. Hydraulic Fluid Recommendations

Hydraulic fluid within the system performs the dual function of lubrication and transmission of power. To insure proper lubrication, system life, and component reliability, fluid selection should be made carefully with the assistance of a reputable supplier. Fluid selection should be acceptable for use with all valves, motors and pumps within the system. Data sheets for fluid selection are available from your local Sales or Engineering representative to order data sheet I-286-S.

The fluid recommendations noted in the data sheet are based on our experience in industry as a hydraulic component supplier. Where special considerations indicate a need to depart from these recommendations, see your sales representative.

E. Cleanliness

To insure your hydraulic system is clean, perform the following steps:

1. Clean (flush) the entire system to remove paint, metal chips, welding shot, etc.
2. Filter each oil change to prevent introduction of contaminants.
3. Provide continuous oil filtration to remove sludge, products of wear and corrosion generated during the life of the system.
4. Provide protection to all areas that can introduce airborne contaminants into the system.
5. Perform regular servicing procedures of filters, breathers, and reservoirs.

F. Overload Protection

A relief valve must be installed in the system as close to the pump as possible. The relief valve limits pressure in the system to a prescribed maximum. The setting of the relief valve depends on the work requirements of the system.

Section VII – Service, Inspection & Maintenance

A. Service Tools

No special tools are required to service this valve series.

B. Inspection

Periodic inspection of the fluid condition and tube or piping connections can save time consuming breakdowns and unnecessary parts replacement. The following should be checked regularly.

1. All hydraulic connections must be kept tight. A loose connection in a pressure line will permit the fluid to leak out. If the fluid level becomes so low as to uncover the inlet pipe opening in the reservoir, extensive damage to the system can result. Loose connections also permit air to be drawn into the system resulting in noisy and/or erratic operation.
2. Clean fluid is the best insurance for long service life. Therefore, check the reservoir periodically for long service life. Therefore, check the reservoir periodically for dirt and other contaminants. If the fluid becomes contaminated, flush the entire system and add new fluid.
3. Filter elements should also be checked periodically for dirt and other contaminants. If the fluid becomes contaminated, flush the entire system and add new fluid.
4. Air bubbles in the reservoir can ruin the valve and other components. If bubbles are seen, locate the source of air and seal the leak.

C. Adding Fluid to the System

When hydraulic fluid is added to replenish the system, pour it through a fine wire screen (200 mesh or finer). When applicable, pump the fluid through a 10 micron filter. DO NOT use a cloth to strain the fluid or lint may enter the system.

D. Adjustments

No periodic adjustments are required other than normal system maintenance.

E. Replacement Parts

Reliable operation throughout the specified operating range is assured only if genuine Vickers parts are used. Sophisticated design processes and material are used in the manufacture of our parts. Substitutions may result in early failure. Part numbers are shown in the parts and service drawings listed in Table 1.

F. Product Life

The service life of this product is dependent upon environment, duty cycle, operating parameters and system cleanliness. Since these parameters vary from application to application, the ultimate user must determine and establish the periodic maintenance required to maximize life and detect potential component failure.

G. Troubleshooting

Table 5 lists the common difficulties experienced with directional valves and systems. It also indicates the probable causes and remedies for each of the troubles listed.

Always remember that many apparent failures may actually be the failure of other parts of the system. The cause of improper operation is best diagnosed with adequate testing equipment and a thorough understanding of the complete hydraulic system.

Trouble	Possible Cause	Remedy
Valve spool fails to move	Dirt in system	Disassemble, clean and flush
	Solenoids inoperative	Check electrical source and solenoids
	Improper assembly	Check proper assembly. Refer to appropriate figure and assembly procedure
	Improper installation connections	Check installation drawings
Valve produces undesirable response	Improper valve assembly	Check parts drawing and installation drawing for proper assembly and installation connections
	Improper installation connections	
	Solenoid wiring reversed	Reverse connections to the solenoids

Table 5. Trouble Shooting Chart

Section VIII – Overhaul



WARNING

Before breaking any circuit connections, be certain the electrical power is off and all branches of the circuit are relieved of trapped pressure. Lower all vertical cylinders. Discharge or isolate accumulators. Block any load whose movement could cause injury to personnel or damage to the equipment.

A. Unit Removal

Refer to Figure 15.

1. Thoroughly clean the exterior of the valve and the area around the valve to prevent contamination of the system during removal.
2. Remove the valve from its subplate or mounting pad as follows:
 - a. If the valve is equipped with the insta-plug feature, loosen the two slotted screws and unplug the electrical wiring from the pilot section.

- b. If the valve has an air operated pilot section, turn off air supply and disconnect the pressure lines from the connection plate.



CAUTION

In the following step make sure electrical power is off, then disconnect the solenoid wiring. Label each wire to provide assembly information.

- c. If the valve has standard electrically operated solenoids, remove the four nameplate screw (1) on top of the pilot section. Move nameplate (2) and gasket (3) aside to expose interior of the wire cavity. Disconnect solenoid wiring.
- d. Loosen the six mounting screws that hold the main stage section to the mounting pad. Be ready to catch the fluid retained inside the lines and valve.
- e. Remove the valve from the mounting pad and set it on a clean work bench. Use a chain lift when necessary.

DG5S4-10*-****-53

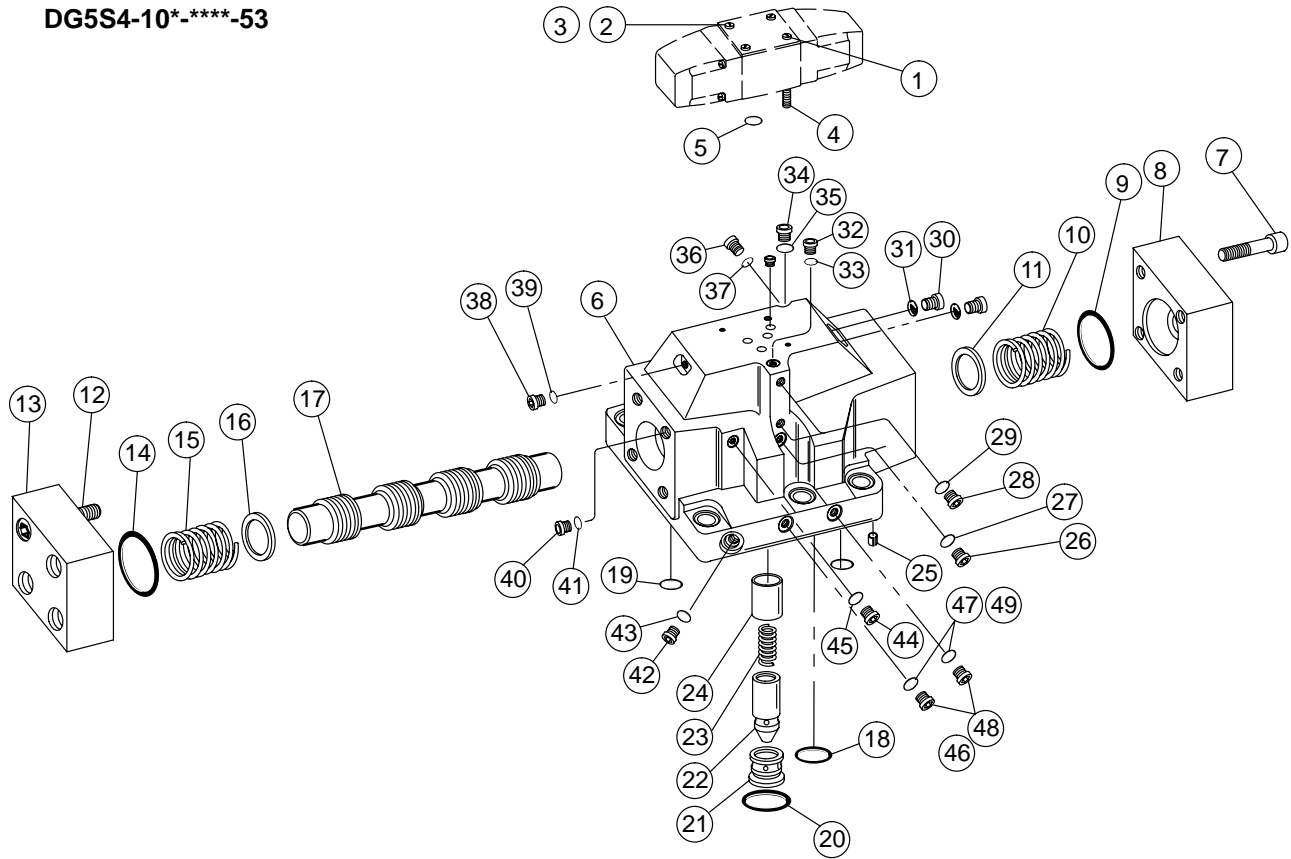

Item	Nomenclature	Quantity
1	Screw	4
2	Nameplate (Pilot Valve	1
3	Gasket	1
4	Screw	4
5	O-Ring	5
6	Body (Main Section)	1
7	Screw	4
8	Cover	1
9	O-Ring	1
10	Spring	1
11	Washer	1
12	Screw	4
13	Cover	1
14	O-Ring	1
15	Spring	1
16	Washer	1
17	Spool	1
18	O-Ring	3
19	O-Ring	2
20	O-Ring	1
21	Seat	1
22	Poppet	1
23	Spring	1
24	Sleeve	1
25	Rest Pin	2
26 - 48 (Consecutive even #'s)	Plug	13
27 - 49 (Consecutive odd #'s)	O-Ring	13

Figure 15. Main Stage Section with Check Valve DG5S4-10*-****-53

B. Disassembly

General

This manual describes the disassembly sequence of a typical DG5S4-10*C-W3-53 two-stage directional valve. See Figures 15 and 18. Slight variations may be noted on your model depending on the type of accessories and unit design. Figure 15 may be used for all models, except pressure centered "D" models regardless of the design. Refer to Figure 17 for pressure centered "D" models. Figure 18 shows the disassembly sequence of a DG4S4-016C-W3*-50 wet armature pilot valve. If your pilot valve is of a different type, refer to Figures 19, 20 or 21.

C. Pilot Valve Removal

Refer to Figure 15.

1. Remove the four attaching screws (4) from the pilot valve. Remove the pilot valve from the main stage body (6).
2. Remove and discard O-Rings (5) from pilot valve mounting face.

NOTE

The following section (D) pertains to main stage disassembly. If your unit does not require main stage disassembly, omit the following section.

D. Main Stage Disassembly

Refer to Figure 15.

1. Loosen the four end cover screws (7) from end cover (8). Be ready to catch any oil trapped inside the unit. Remove the end cover and discard O-Ring (9).
2. Remove spring (10) and washer (11) from main stage spool (17). NOTE: Spring (10) and washer (11) do not exist on spring offset "A" or floating type models.
3. Loosen the four screws (12) from end cover (13). Remove the end cover and discard O-Ring (14).
4. If applicable, remove spring (15) and washer (16) from main stage spool (17).
5. Remove main stage spool (17) from body (6).
6. Turn the body (6) on its side and remove O-Rings (18, 19 and 20) from mounting face.

NOTE

The following step (7) pertains to integral check valve models only. DO NOT remove check valve parts unless inspection or unit operation indicates a check valve problem. If check valve removal is necessary, perform step (7).

7. Select the correct screw listed in Table 6. Obtain a piece of pipe or tubing with an inside diameter that is slightly larger than outside diameter of seat.

Model	Screw Dia./Thread Type	Screw Length
DG5S4-04	.5000-13 UNC-2B	76.2mm (3")
DG5S4-06	.5625-18 UNF-2B	
DG5S4-H06	.875-14 UNF-2B	
DG5S4-10	1.125-7 UNC-2B	
DG5S4-H8	.750-16 UNF-2B	
DG5S4-8	.750-16 UNF-2B	

Table 6. Screw Tabulation for Seat (21) Removal

Also obtain a flat washer. Remove seat (21), Figure 15, per instructions noted in Figure 16. Remove poppet (22) and spring (23). DO NOT remove sleeve (24).

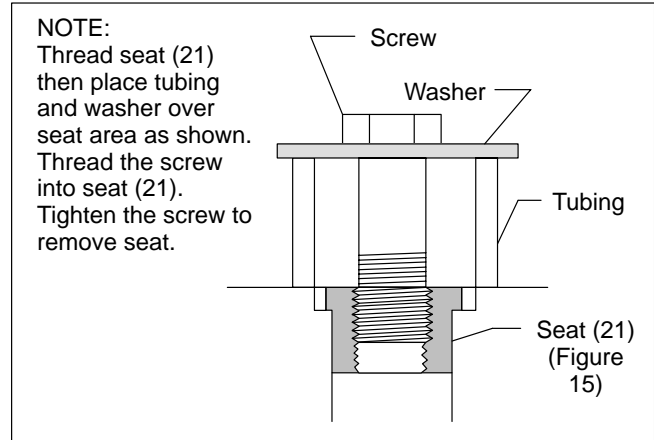

Figure 16. Check Valve Seat Removal

8. If necessary, remove rest pins (25) with vise grip pliers.
9. Remove SAE straight thread construction plugs and O-Rings (26 through 49) from body (6). DO NOT remove construction plugs if your unit is equipped with the pipe plug variety (50 and 51 design models).

NOTE

DO NOT remove the internal plugs of body unless inspection reveals a problem.

E. Pilot Valve Disassembly

Refer to Figure 18.

NOTE

The following steps (1 through 9) describe the disassembly sequence of a DG4S4-01**-W3*-50 wet armature pilot valve. If your pilot valve is of a different type, refer to figures 19, 20, or 21 and follow the item number sequence for disassembly.

1. Remove the two screws (1) from solenoid coil (2) and remove the coil. Remove and discard gasket (3).
2. Remove and discard O-Ring (4) from exposed core tube S/A (7).
3. Remove the two screws (5) from flange (6). Then remove the flange and core tube S/A from body (38). Remove and discard O-Ring (8) from core tube S/A.
4. Remove push pin (9), pole face (10), armature (11) and manual plunger (12) from core tube (7). Remove and discard O-Ring (13) from manual plunger (12).

DG5S4-10*D-W(3)-*53

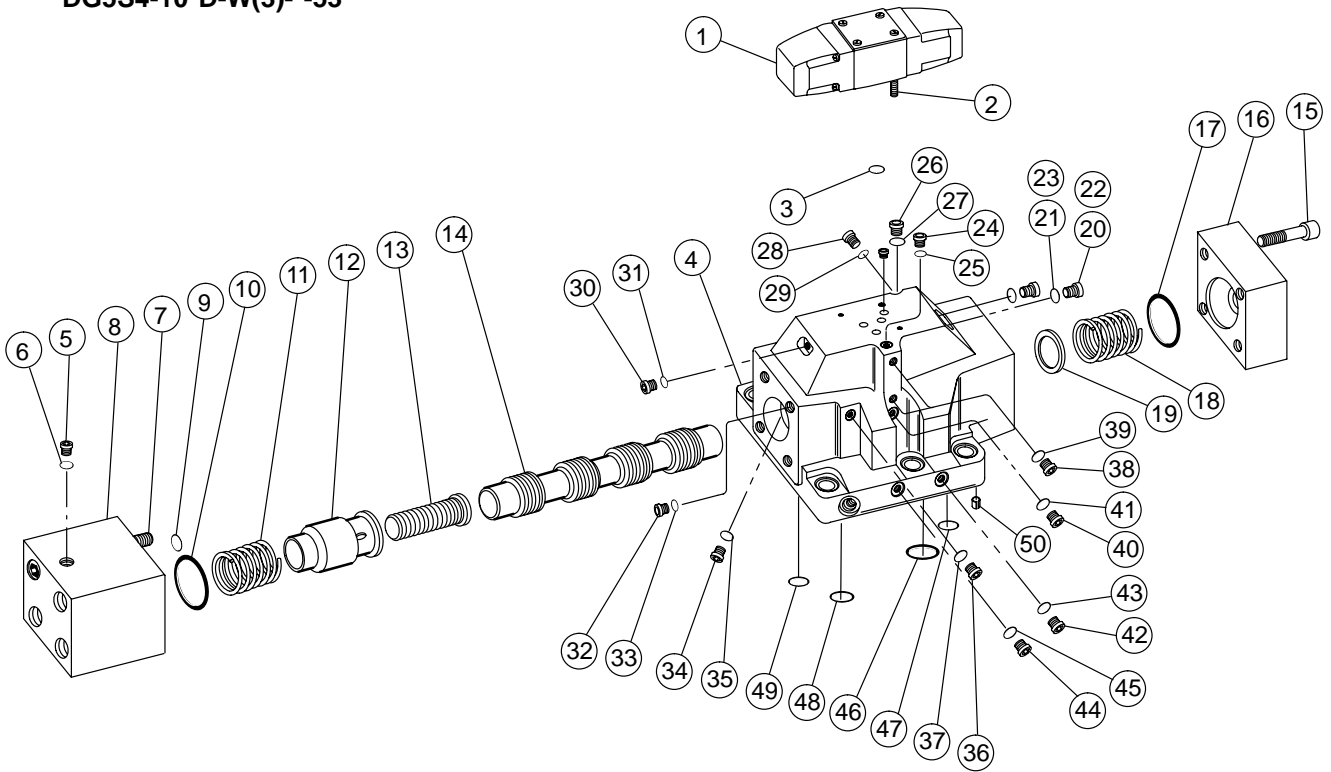

Item	Nomenclature	Quantity
1	Pilot Valve	1
2	Screws	4
3	O-Rings	5
4	Body	1
5	Plug	1
6	O-Ring	1
7	Screw	4
8	Cover	1
9	O-Ring	1
10	O-Ring	1
11	Spring	1
12	Sleeve	1
13	Piston	1
14	Spool	1
15	Screw	4
16	Cover	1
17	O-Ring	1
18	Spring	1
19	Washer	1
20 - 45	Plugs & O-Rings	13 each
46	O-Ring	4
47	O-Ring	1
48	O-Ring	1
49	O-Ring	1
50	Rest Pin	2

Figure 17. Main Stage Section, Pressure Centered "D" Model (DG5S4-10*D-W(3)-*53)

DG4S4-01-W3-51**

NOTE:

Model Source Code

- DG4S4-01-**A-50 A
- DG4S4-01-**B-50 B
- DG4S4-01-**C-50 C
- DG4S4-01-**N-51 N

∅ Included in serviceable core tube S/A

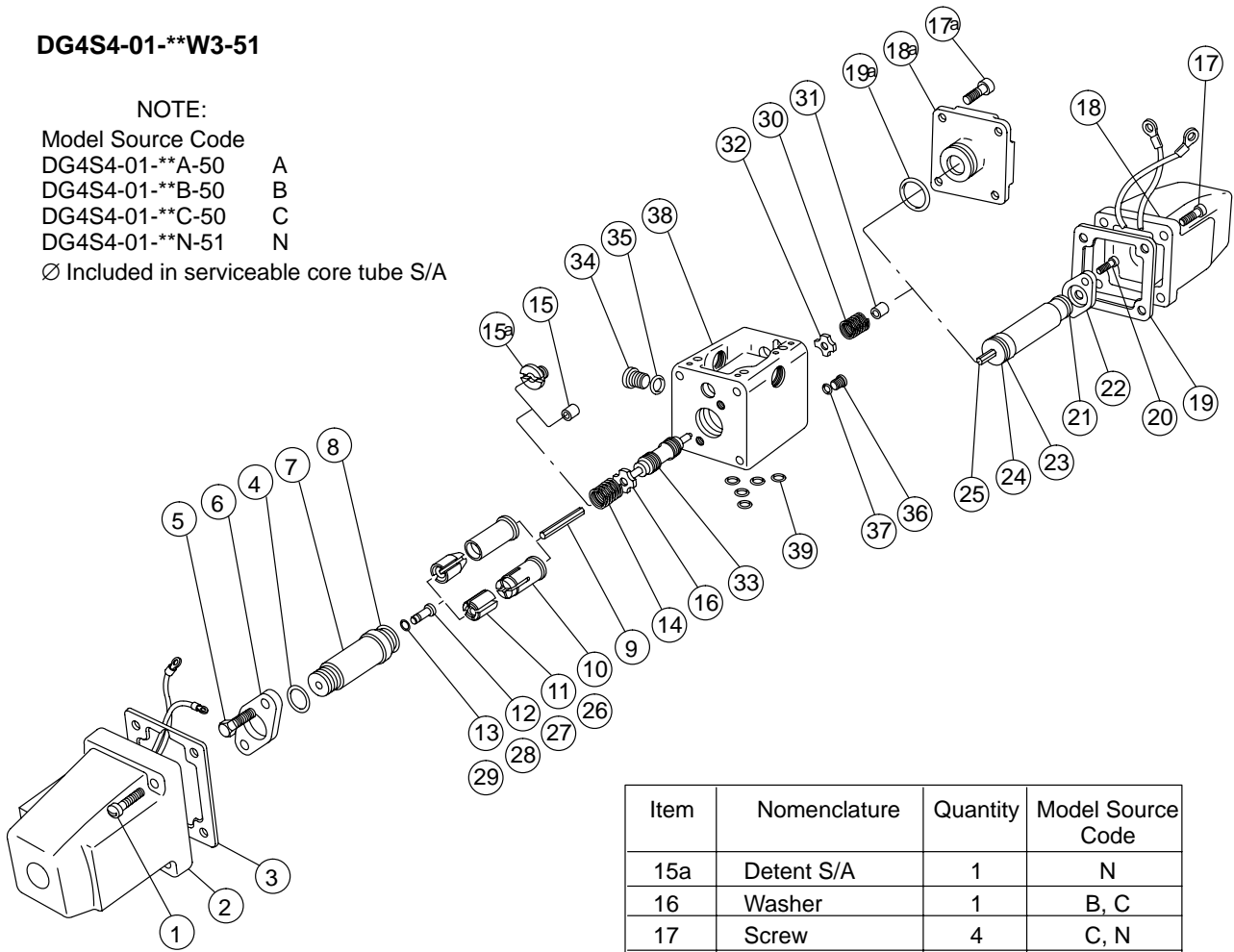

Item	Nomenclature	Quantity	Model Source Code
1	Screw	4	A, B, C, N
2	Coil S/A	1	A, B, C, N
3	Gasket	1	A, B, C, N
4 ∅	O-Ring	1	A, B, C, N
5	Screw	2	A, B, C, N
6	Flange	1	A, B, C, N
7 ∅	Core Tube	1	A, B, C, N
8 ∅	O-Ring	1	A, B, C, N
9 ∅	Push Pin	1	A, B, C, N
10 ∅	Pole Face	1	A, B, C, N
11 ∅	Armature	1	A, B, C, N
12 ∅	Manual Plunger	1	A, B, C, N
13 ∅	O-Ring	1	A, B, C, N
14	Spring	1	B, C, N
15	Spacer	1	C

Item	Nomenclature	Quantity	Model Source Code
15a	Detent S/A	1	N
16	Washer	1	B, C
17	Screw	4	C, N
17a	Screw	4	A, B
18	Coil S/A	1	C, N
18a	Cover	1	A, B
19	Gasket	1	C, N
19a	O-Ring	1	A, B
20	Screw	2	C, N
21	O-Ring	1	C, N
22	Flange	1	C, N
23	O-Ring	1	C, N
24	Core Tube	1	C, N
25	Push Pin	1	C, N
26 ∅	Pole Face	1	C, N
27 ∅	Armature	1	C, N
28 ∅	Manual Plunger	1	C, N
29 ∅	O-Ring	1	C, N
30	Spring	1	A, B, C
31	Spacer	1	B, C, N
32	Washer	1	B, C
33	Spool	1	A, B, C, N
34	Plug	1	A, B, C, N
35	O-Ring	1	A, B, C, N
36	Plug	1	A, B, C, N
37	O-Ring	1	A, B, C, N
38	Body	1	A, B, C, N
39	O-Ring	5	A, B, C, N

Figure 18. Wet Armature, Pilot Valve DG4S4-01-**W3-51

DG4S4-01-50

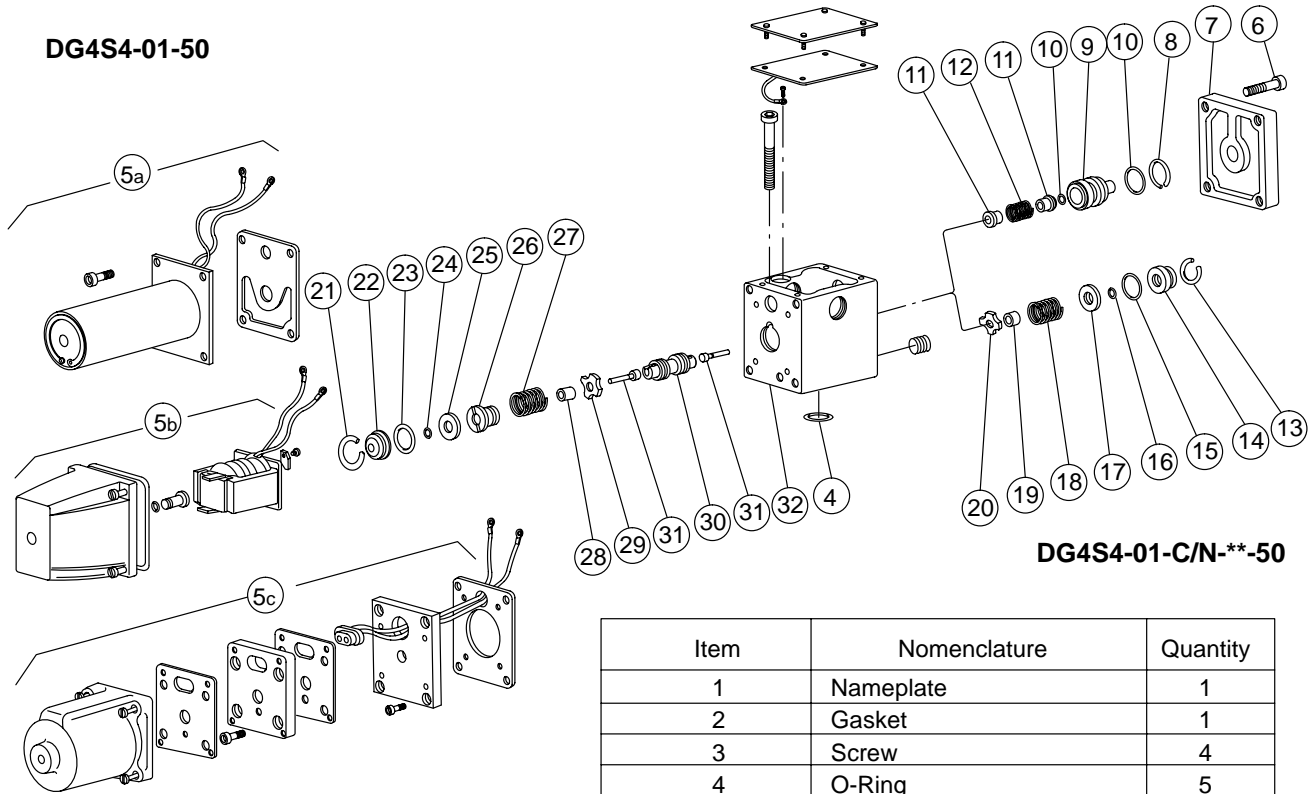

DG4S4-01-C/N-**-50

Item	Nomenclature	Quantity
1	Nameplate	1
2	Gasket	1
3	Screw	4
4	O-Ring	5
5A	DC Solenoid Assembly	2
(offset "A" units)	DC Solenoid Assembly	1
5B	AC Solenoid Assembly	2
(offset "A" units)	AC Solenoid Assembly	1
5C	Oil Immersed Solenoid Assy.	2
(offset "A" units)	Oil Immersed Solenoid Assy.	1
6	Screw	4
7	Cover	1
8	Snap Ring	1
9	Guide	1
10	O-Rings (Guide)	1
11	Limiter	2
12	Spring	1
13	Snap Ring	1
14	Guide	1
15	O-Ring	1
16	O-Ring	1
17	Washer (Seal Retainer)	1
18	Spring	1
19	Spacer	1
20	Washer (Spring Centering)	1
21	Snap Ring	1
22	Guide	1
23	O-Ring	1
24	O-Ring	1
25	Washer (Seal Retainer)	1
26	Detent Assembly	1
27	Spring	1
28	Spacer	1
29	Washer (Spring Centering)	1
30	Spool	1
31	Push Pin	2
32	Body & Plug	1

Figure 19. DG4S4-01-50, DC, Air Gap & Oil Immersed Type Pilot Valves

DG4V-3--M-40**

NOTE:

Model Source Code
 DG4V-3-**-A-40 A
 DG4V-3-**-B-40 B
 DG4V-3-**-C-40 C
 DG4V-3-**-F-40 F
 DG4V-3-**-N-40 N

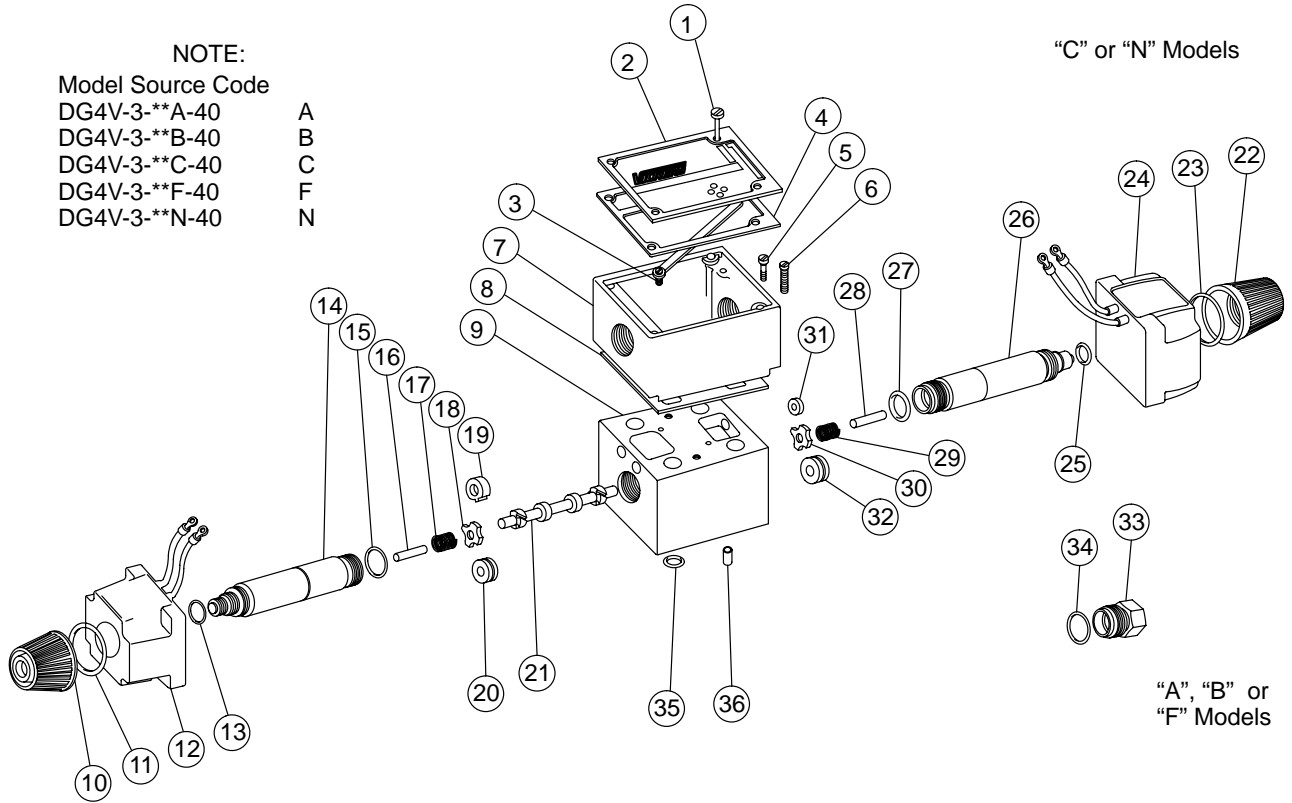

Item	Nomenclature	Quantity	Model Source Code
1	Screw	4	A, B, C, F, N
2	Carrier	1	A, B, C, F, N
3	Screw	1	A, B, C, F, N
4	Gasket/Retainer	1	A, B, C, F, N
5	Screw	2	A, B, C, F, N
6	Screw	1	A, B, C, F, N
7	Terminal Box	1	A, B, C, F, N
8	Gasket	1	A, B, C, F, N
9	Body	1	A, B, C, F, N
10	End Cap	1	A, B, C, F, N
11	O-Ring	1	A, B, C, F, N
12	Coil S/A	1	A, B, C, F, N
13	O-Ring	1	A, B, C, F, N
14	Core Tube S/A	1	A, B, C, F, N
15	O-Ring	1	A, B, C, F, N
16	Push Pin	1	A, B, C, F, N
17	Spring	1	A, B, C, N
18	Washer	1	C, F

Item	Nomenclature	Quantity	Model Source Code
19	Detent S/A	1	N
20	Washer	1	A
21	Spool	1	A, B, C, F, N
22	End Cap	1	C, N
23	O-Ring	1	C, N
24	Coil S/A	1	C, N
25	O-Ring	1	C, N
26	Core Tube S/A	1	C, N
27	O-Ring	1	C, N
28	Push Pin	1	C, N
29	Spring	1	A, B, C, F, N
30	Washer	1	B, C, F
31	Washer	1	F
32	Washer	1	N
33	End Cap	1	A, B, F
34	O-Ring	1	A, B, F
35	O-Ring	1	A, B, C, F, N
36	Pin	1	A, B, C, F, N

Figure 20. DG4V-3*W3-40 Pilot Valve

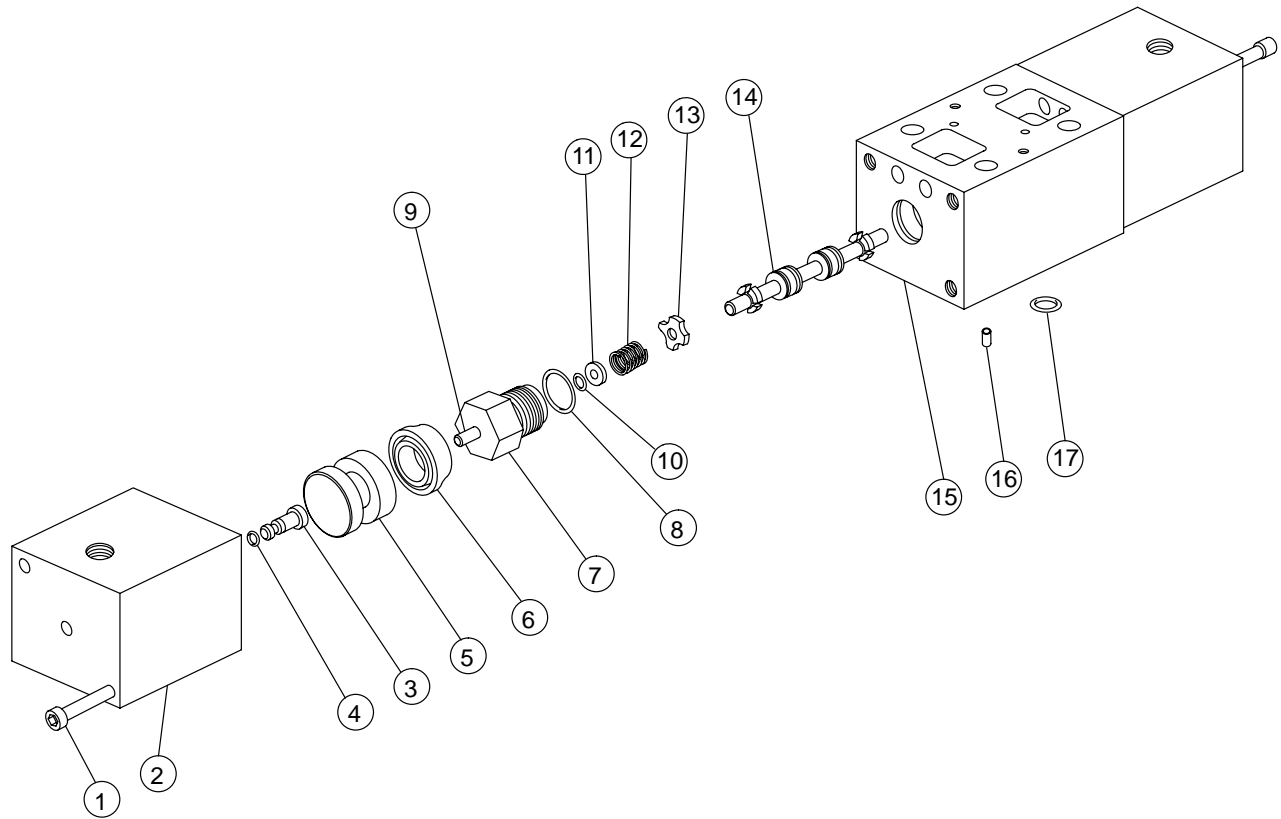

Item	Nomenclature	Quantity
1	Screw	4
2	End Cover	2
3	Manual Plunger	2
4	O-Ring	2
5	Plunger	2
6	Seal	2
7	Guide	2
8	O-Ring	2
9	Pin	2
10	O-Ring	2
11	Retainer	2
12	Spring	2
13	Washer	2
14	Spool	1
15	Body	1
16	Pin	1
17	O-Ring	4

Figure 21. DG18V-3-C-40 Air Operated Pilot Valve for DG19S4-**-52 Two-Stage Unit

5. Remove spring (14), spacer (15) and washer (16) from body bore.

NOTE

Some parts may not exist on your valve. Check the omit codes on Figure 18. On "N" type pilot valves, detent SA (16a) replaces washer (16). Remove the detent S/A (16a) but DO NOT remove retaining ring from the detent.

6. If the pilot valve is equipped with two solenoids, remove parts (17 through 25 and 30 through 32) from opposite end of body (38).

NOTE

Spring (30) and washer (32) do not exist on "N" type pilot valves.

NOTE

The following step (7) pertains to spring offset "A" and spring centered "B" pilot valves only.

7. Remove the four screws (17a) from end cover (18a) and then remove the end cover. Remove and discard O-Ring (19a) from end cover. Remove parts (30 through 32) from body bore.

NOTE

Spacer (31) and washer (32) do not exist on spring offset "A" models.

8. Remove the pilot spool (33) from body (38).

9. Secure the body and remove plugs (34 and 36) from body (38). Remove O-Rings (35 and 37) from plugs and discard.

F. Cleaning

All parts must be thoroughly cleaned and kept clean during inspection and assembly. The close tolerance of the valve bodies and spools make this requirement critical. Clean all parts with a commercial solvent that is compatible with the system fluid. Compressed air may be used to clean the valve, but it must be filtered to remove water and contamination. Clean compressed air is particularly useful for cleaning spool orifices, body passages and drying parts.

NOTE

If the spool shows and indication of damage due to contamination, drain the fluid from the system., flush all lines and clean the reservoir. New filter elements should be installed and new fluid should be added to the reservoir.

G. Inspection, Repair and Replacement

1. Check that all internal passages are clean and free from obstruction. Examine all mating surfaces for nicks and burrs. Minor nicks and burrs can be removed with crocus cloth or an India stone.



CAUTION

DO NOT stone the edges of spool sealing lands. Remove minor burrs with #500 grit paper. Use the paper very lightly on the outer diameter of each spool.

2. Inspect all screws for evidence of damaged threads. If threads are damaged, replace the screws.

3. Inspect all springs for distortion or wear. The ends of the springs shall be square and parallel to each other. Replace springs that are damaged or distorted.

4. Check push pins, pole faces, washers and manual plungers for burrs, cracks or mushrooming. Replace all parts that show evidence of wear.

5. Visually inspect the internal coring (bore) of each body for heavy scratches or erosion across the spool land sealing areas. If such evidence is found, replace the valve. If the body bore passes inspection, check bore to spool clearance as follows:

a. Lubricate spools and body bores with clean system fluid. Make sure the parts are clean.

b. Insert the spool into its body bore. Rotate the spool 360° while moving it back and forth. Observe the following:

If the spool does not move freely, the spool is sticking inside the body bore. Remove the spool and recheck the spool and body bore for scratches and/or burrs. Remove any minor scratches or burrs with India stone or crocus cloth. Repeat steps (a) and (b). (NOTE: An alternate test is to turn the body on end and allow gravity to pull the spool from the body into your hand. If the spool does not move under the influence of gravity, the spool is sticking inside the body bore.) If the spool binding persists, replace the valve.

Check the feel of the spool. If side movement of the spool can be felt within the body bore, the body/spool clearances are excessive. A new spool and body have a select fit of approximately 0.0002-0.0003 inch. Body/spool clearances in excess of this value may still work satisfactory in your system; however, limitations are dependant on how much leakage your system can tolerate. Normally, excessive body/spool clearances dictate replacing the entire valve.

NOTE

If a new spool is installed into a new or used body, break the feathered edges of the spool balancing grooves with a three or four cornered India stone. See Figure 22. Lightly polish the spool with #500 grit paper. Wash the spool in clean solvent. Repeat steps (a) and (b).

NOTE

The following step (6) pertains to detented "N" pilot valves only.

6. Check the detent by moving the push pin through the detent. A steady frictional force should be observed. If the detent force is weak (less than 1 lb.), replace the detent subassembly. The detent should be assembled on the polished end of the spool (DG4S4-01*N-W-51) models.

7. Perform a continuity test on each solenoid coil S/A. Resistance values will vary with the voltage rating of the coil. Refer to Table 7. This test is superficial, but a more rigorous test requires special equipment. If the coil seems to be burned or extreme heat is encountered during operation, the coil may be shorted. Make sure the correct voltage is being applied to the coil.

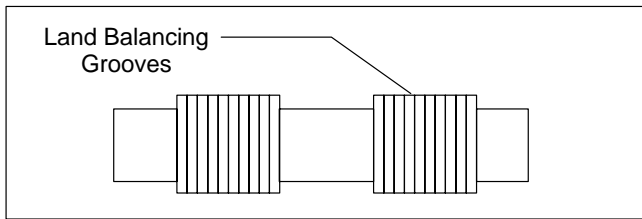

Figure 22. Spool Balancing Grooves

Voltage	Coil Resistance
6 DC	1.5 Ohms
12 DC	5 Ohms
24 DC	24 Ohms
48 DC	80 Ohms
115 DC	480 Ohms
230 DC	1800 Ohms
115 AC (60 Hz)	13 Ohms
230 AC (60 Hz)	50 Ohms
460 AC (60 Hz)	204 Ohms

Table 7. Coil Resistance

H. Assembly

Before assembly, obtain the correct seal kit as noted in the parts drawing. Lubricate all O-Rings and internal parts with clean system fluid to provide initial lubrication and facilitate assembly.

Check the model code to determine correct assembly of units. If a L.H. suffix appears in the model code, the pilot valve solenoid is assembled left hand. In such cases, all pilot valve parts are reversed except the body and spool.

Assembly will be in reverse of the disassembly sequence shown in Figures 15 and 18 unless otherwise indicated.

1. Assembly of Main Stage Section

Refer to Figure 15.

a. Install O-Rings on construction plugs. Lubricate plug threads and install plugs into body (6). Torque plugs to value noted in parts drawing. Refer to Table 1.

b. Tap new rest pin(s) (25) into place if removed during disassembly.

NOTE

The following step (c) pertains to integral check valve models only.

c. Place spring (23) into poppet (22) and then install the poppet into pressure port (P) cavity as shown. Obtain a suitable push rod and press seat (21) (large diameter face up) into pressure port (P) cavity. Use an arbor press for this operation. Install O-Ring (20) into pressure port mounting groove.

d. Install O-Rings (19) into "X" and "Y" port mounting grooves.

e. Install O-Rings (18) into port mounting grooves "A", "B" and "T".

f. Lubricate spool lands with clean system fluid and then carefully install spool (17) into main body bore. Make sure the spool moves freely inside the body bore and is oriented properly. (See parts drawing.)

g. Install washer (16) and spring (15) on end of spool (17). (NOTE: Spring (15) and washer (16) do not exist on spring offset "A" or "floating" type models.)

h. Install O-Ring (14) into cover (13) as shown.

i. Fasten cover (13) to end of body (6) with four screws (12). Torque the screws (12) to value note in parts drawing. Make sure cover is oriented properly (in line with body contours).

j. If applicable, install washer (11) and spring (10) on opposite end of spool. (NOTE: Spring (10) and washer (11) do not exist on "A" or "floating" type models).

k. Install O-Ring (9) into cover (8).

l. Fasten cover (8) to end of body with four screws (7). Torque screws to value shown in parts drawing.

2. Assembly of Pilot Valve Section

Refer to Figure 18.

a. Spring centered "B" and "C" models:

1. Install O-Ring (35 and 37) on plugs (34 and 36). Lubricate plug threads and install into body (38) as shown. Torque plugs to the value shown in part drawing. See Table 1.

2. Lubricate pilot spool (33), then carefully install spool into the body bore.

3. Assemble washer (32) on end of spool (33) with sharp break edge toward outside of body.

4. Install spacer (31) on end of pilot spool with spacer counterbore facing push pin (25).

5. Install spring (30) into body bore.

NOTE

The following steps (6 through 8) pertain to spring centered "B" models only.

6. Assemble O-Ring (19a) on cover (18a), then assemble cover to valve body (38) with screws (17a). Torque screws to the value shown in parts drawing.

7. Install washer (16) on end of valve spool with sharp break edge toward outside of valve.

8. Install spring (14) into body cavity over washer.

NOTE

The following steps (9 through 16) pertain to spring centered "C" models only. If your valve is equipped with serviceable core tub S/A (W3), perform step (9). Omit step (9) if your model has non-serviceable core tubes (W). Non serviceable core tubes CANNOT be disassembled.

9. Install O-Ring (29) on manual plunger (28). Lubricate plunger (28) and O-Ring (29) with petroleum jelly.

a. Insert manual plunger (28) into the hole at the bottom of core tube (24) with the shoulder of the plunger on the inside of the core tube.

b. Install armature (27) into core tube as shown. Make sure the armature fits over the manual plunger at the bottom of the tube. Use the correct armature S/A for AC and DC operation. See parts drawing.

c. Install pole face (26) into the core tube on top of the armature.

d. Insert push pin (25) into pole face hole. Assemble O-Ring (23) into groove of pole face.

10. Assemble flange (22) on core tube (24) with chamfer side facing body (38).

11. Assemble core tube (24) and flange (22) to body (38) with screws (20). Torque screws to value shown in parts drawing.

12. Install washer (16) on end of spool with sharp break edge toward outside of valve.

13. Install spacer (15) with chamfer toward push pin.

14. Install spring (14) into body (38) over spacer (15).

15. Install O-Ring (21) over core tube (24) and into its O-Ring groove.

16. Insert two screws (17) through coil S/A (18). Place gasket (19) over the screws and assemble coil over core tube. Thread coil wires into body cavity. Torque screws to the value shown in parts drawing.

NOTE

The following steps (17 through 25) pertain to (B & C) spring centered models.

17. Install O-Ring (13) on manual plunger (12). Lubricate with petroleum jelly.

18. Insert manual plunger (12) into hole at the bottom of core tube (7) with the shoulder of the plunger on the inside of the core tube.

19. Install armature (11) into core tube as shown. Make sure the armature fits over the manual plunger at the bottom of the core tube. Use correct armature S/A for AC and DC operation. See parts drawing.

20. Install pole face (10) into core tube (7) on top of armature (11).

21. Insert push pin (9) into pole face hole. Assemble O-Ring (8) in groove of pole face.

22. Assemble flange (6) on core tube (7) with chamfer side facing body (38).

23. Assemble core tube (7) and flange (6) against body (38) with screws (5). Torque screws to value shown in parts drawing.

24. Install O-Ring (4) over core tube S/A (7) and into the O-Ring groove.

25. Insert two screws (1) through coil S/A (2). Place gasket (3) over the screws and assemble coil over core tube. Thread coil wires into body cavity. Torque screws to the value shown in parts drawing.

b. Spring offset "A" models:

See Figure 18.

NOTE

Observe the model code. If left hand (LH) assembly is required, reverse all pilot parts except body and spool.

1. Install O-Rings (35 and 37) on plugs (34 and 36). Lubricate plug threads and install into body (38) as shown. Torque the plugs to value shown in parts drawing.

2. Lubricate the pilot spool (33), then carefully install spool into the body bore. Orient small end of spool toward cover (18a).

3. Install spring (30) into body bore.

4. Assemble O-Ring (19a) into groove of cover (18a). Lubricate O-Ring with petroleum jelly and place cover against end of valve body (38). Thread screws (17a) through cover into body and torque to the value shown in parts drawing.

5. Assemble and install solenoid S/A parts and coil S/A. Perform steps a.17. through a.25.

c. Detent "N" models:

Refer to Figure 18.

1. Install O-Rings (35 and 37) on plugs (34 and 36). Lubricate plug threads and install plugs into body (38) as shown. Torque the plugs to value shown in parts drawing.

2. Lubricate the pilot spool (33), then carefully install spool (33) into the body bore. Polished end of spool must face detent (15a) end of valve.

3. Install spring (14) and detent (15a) over end of valve spool.

4. Assemble spacer (31) over the end of spool (33) with chamfered end of spacer facing push pin (25).

5. Assemble core tubes and coils to ends of the valve. Perform steps a.9 through a.11 and a.15 through a.25.

3. Assembly of Pilot Valve to Main Stage Section:

Refer to Figure 15.

a. Apply a heavy amount of petroleum jelly to O-Rings (5) and pilot valve mounting face grooves. Install O-Rings into pilot valve.

b. Assemble a lock washer on each of the four screws (4). Lubricate screw threads and insert screws through pilot valve body.

c. Line up the port holes and screw holes. Make sure O-Rings do not slip out of position. Attach pilot valve to main stage section and thread screws into valve hand tight. Torque screws evenly to value shown in parts drawing. DO NOT OVER TORQUE.

d. Mount the two stage valve on a manifold or subplate. Refer to installation drawing, Table 1, for instructions and bolt kit number.

e. Connect electrical power to solenoid wire leads. If an air operated pilot valve is used, connect the air lines to the connection plate.

f. Install nameplate (2) and gasket (3) on pilot valve body if previously removed.

g. Insert four screws through nameplate (2) and gasket (3). Secure nameplate to the pilot valve body.

Section IX – Internal Body Passages & Plug Locations

Two stage directional valves can be converted to different operational modes, i.e., internal/external, pilot pressure or drain, fast response, etc. To accomplish this, internal plugs must be removed or added within the main stage body passages.

Table 8 is a list of basic models with the incorporated operational mode changes. Each model is referenced to a particular figure. The figures illustrate internal passages and plug locations.

Operational Mode Change
(Reference model code, Table 2)

- * - Standard
- X - Fast response option
- E - External pilot pressure
- K/R/S - Integral check valve
- T - Internal pilot drain



CAUTION

DO NOT change internal plugs within main stage body unless power is off and system pressure is relieved.

Basic Model Description	Reference
DG5S4-04**-*-40	Figure 23a
DG5S4-04**X-*-40	
DG5S4-04**E-*-40	
DG5S4-04**X-E-*-40	
DG5S4-04**-K/R/S-*-40	Figure 23b
DG5S4-04**E-K/R/S-*-40	
DG5S4-04**X-K/R/S-*-40	
DG5S4-04**X-E-K/R/S-*-40	
DG5S4-04**T-*-40	Figure 23c
DG5S4-06**-*-51	Figure 24a
DG5S4-06**X-*-51	
DG5S4-06**E-*-51	
DG5S4-06**X-E-51	
DG5S4-06**-K/R/S-*-51	Figure 24b
DG5S4-06**E-K/R/S-*-51	
DG5S4-06**X-K/R/S-*-51	
DG5S4-06**X-E-K/R/S-*-51	
DG5S4-06**T-*-51	Figure 24c
DG5S4-H06**-*-51	Figure 25a
DG5S4-H06**X-*-51	
DG5S4-H06**E-*-51	
DG5S4-H06**X-E-*-51	
DG5S4-H06**-K/R/S-*-51	Figure 25b
DG5S4-H06**E-K/R/S-*-51	
DG5S4-H06**X-K/R/S-*-51	
DG5S4-H06**X-E-K/R/S-*-51	

Basic Model Description	Reference
DG5S4-H06**T-*-51	Figure 25c
DG5S4-10**-*-51/53	Figure 26a
DG5S4-10**X-*-51/53	
DG5S4-10**E-*-51/53	
DG5S4-10**X-E-*-51/53	
DG5S4-10**-K/R/S-*-51/53	Figure 26b
DG5S4-10**E-K/R/S-*-51/53	
DG5S4-10**X-K/R/S-*-51/53	
DG5S4-10**X-E-K/R/S-*-51/53	
DG5S4-10**T-*-51/53	Figure 26c
DG5S-(H)8**-*-10/20	Figure 27a
DG5S-(H)8**X-*-10/20	
DG5S-(H)8**E-*-10/20	
DG5S-(H)8**X-E-*-10/20	
DG5S-(H)8**-K/R/S-*-10/20	Figure 27b
DG5S-(H)8**E-K/R/S-*-10/20	
DG5S-(H)8**X-K/R/S-*-10/20	
DG5S-(H)8**X-E-K/R/S-*-10/20	
DG5S-(H)8**T-10/20	Figure 27c
DG5S4-H06*D-51	Figure 24a (Internal plug locations only)
DG5S-8*D-*-10	
DG5S4-06*D-*-51	
DG5S4-10*D-*-51/53	

Table 8. Internal Passages & Plug Tabulation

Section X – Start-up and Test

A. Start-up

Start the system and sequence the unit through all positions while watching for appropriate movement of actuators. Improper or erratic movement of the actuators may indicate incorrect assembly of the unit or presence of trapped air.

B. Test

A test stand having regulated flow, temperature control and special fixtures is required to fully test the performance of the rebuilt unit. Because of this, only the functional test shown in the start-up paragraph is given. If such a test stand is available, test the unit to the requirements set forth in the installation drawings.

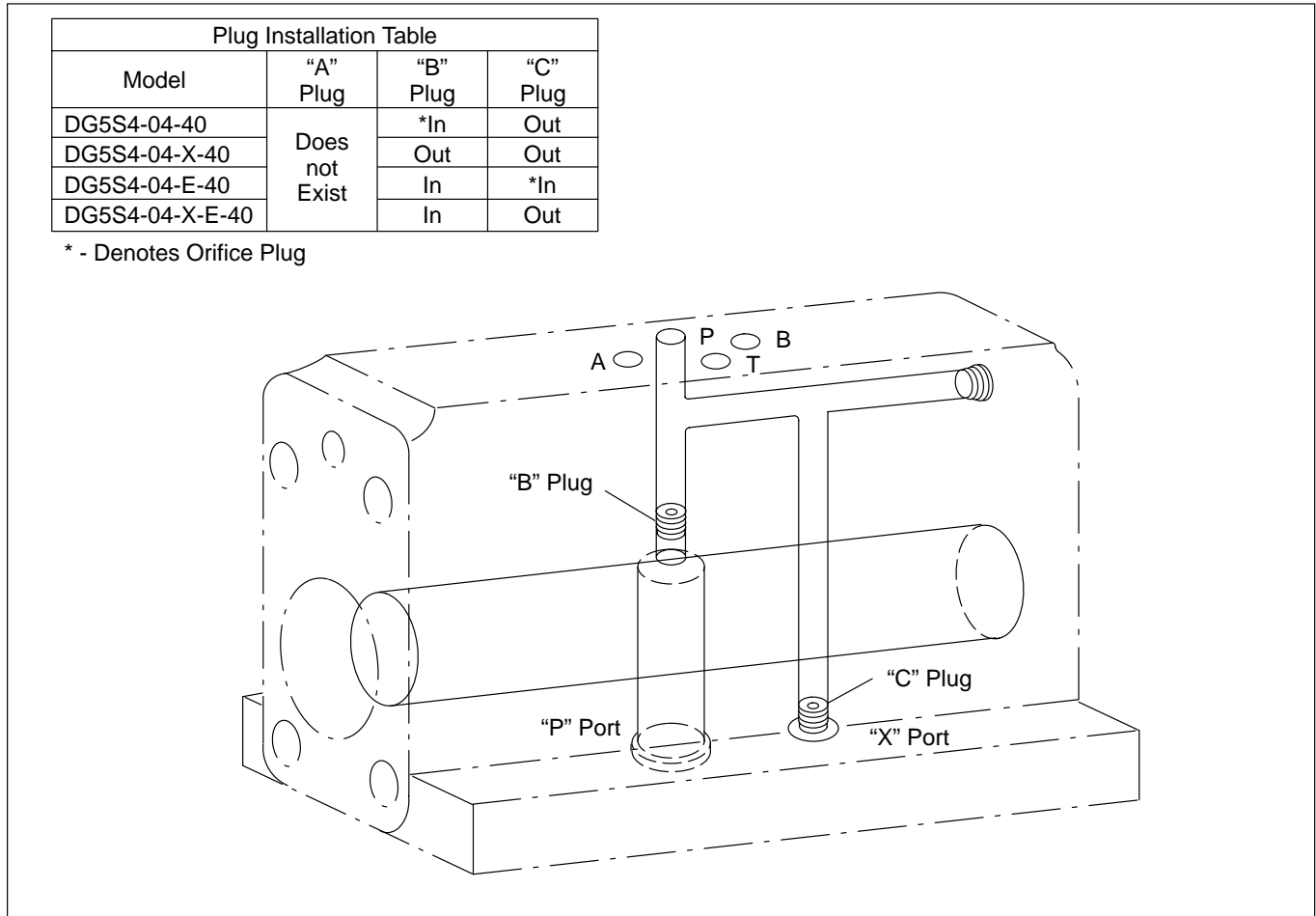

Figure 23a. DG5S4-04-X-40 Internal Pressure Passages & Plug Locations

Plug Installation Table			
Model	"A" Plug	"B" Plug	"C" Plug
DG5S4-04-K/R/S-40	*In	In	Out
DG5S4-04-X-K/R/S-40	Out	In	Out
DG5S4-04-E-K/R/S-40	In	In	*In
DG5S4-04-X-E-K/R/S-40	In	In	Out

* - Denotes Orifice Plug

NOTE:
 Open Center Spools 0, 4, 8 & 9 cannot function unless External Pilot Pressure "E" or a 50/75 psi Check "R"/"S" is used.

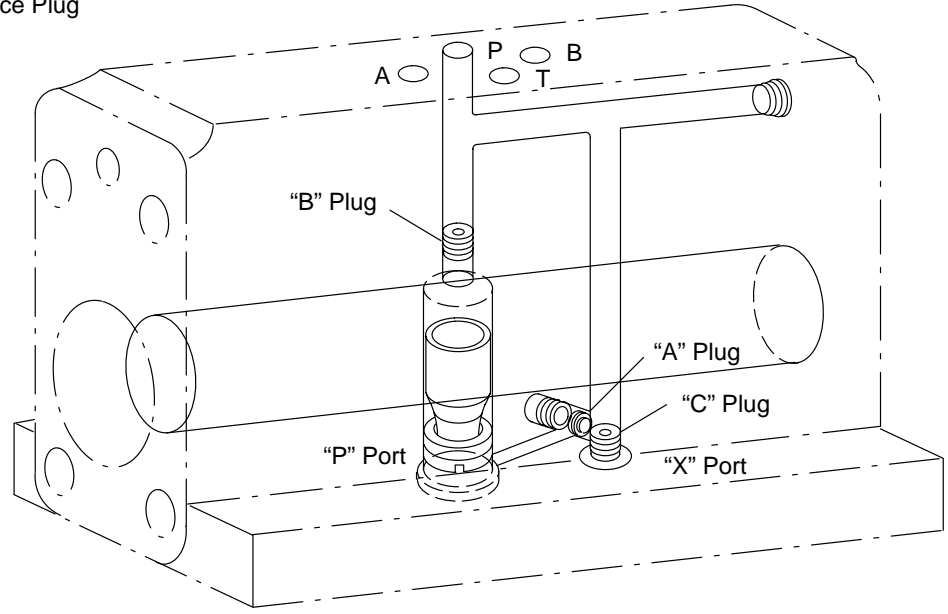

Figure 23b. DG5S4-04-(K/R/S)-40 Internal Pressure Passages & Plug Locations

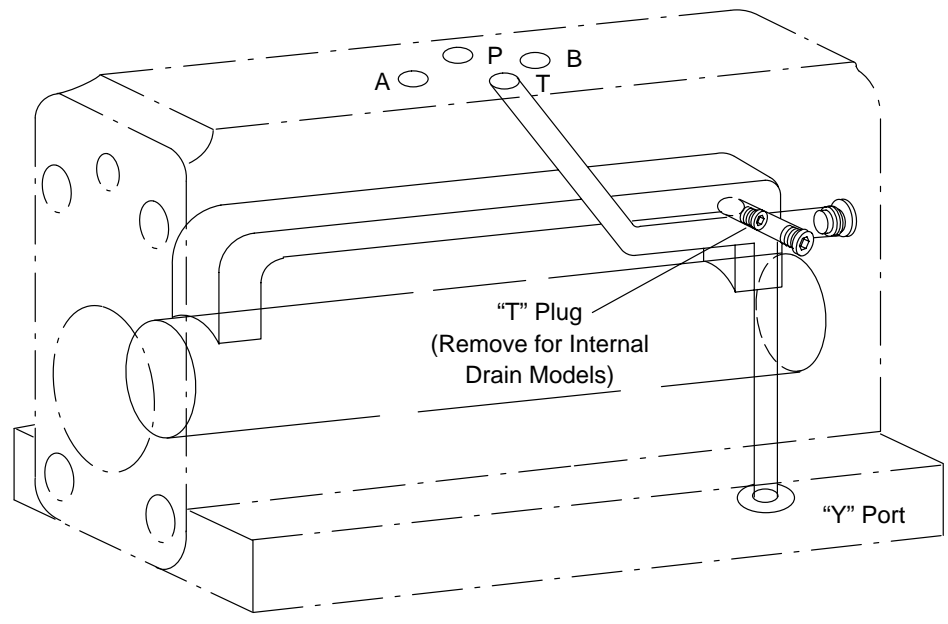

Figure 23c. DG5S4-04-T-40 Internal Pressure Passages & Plug Locations

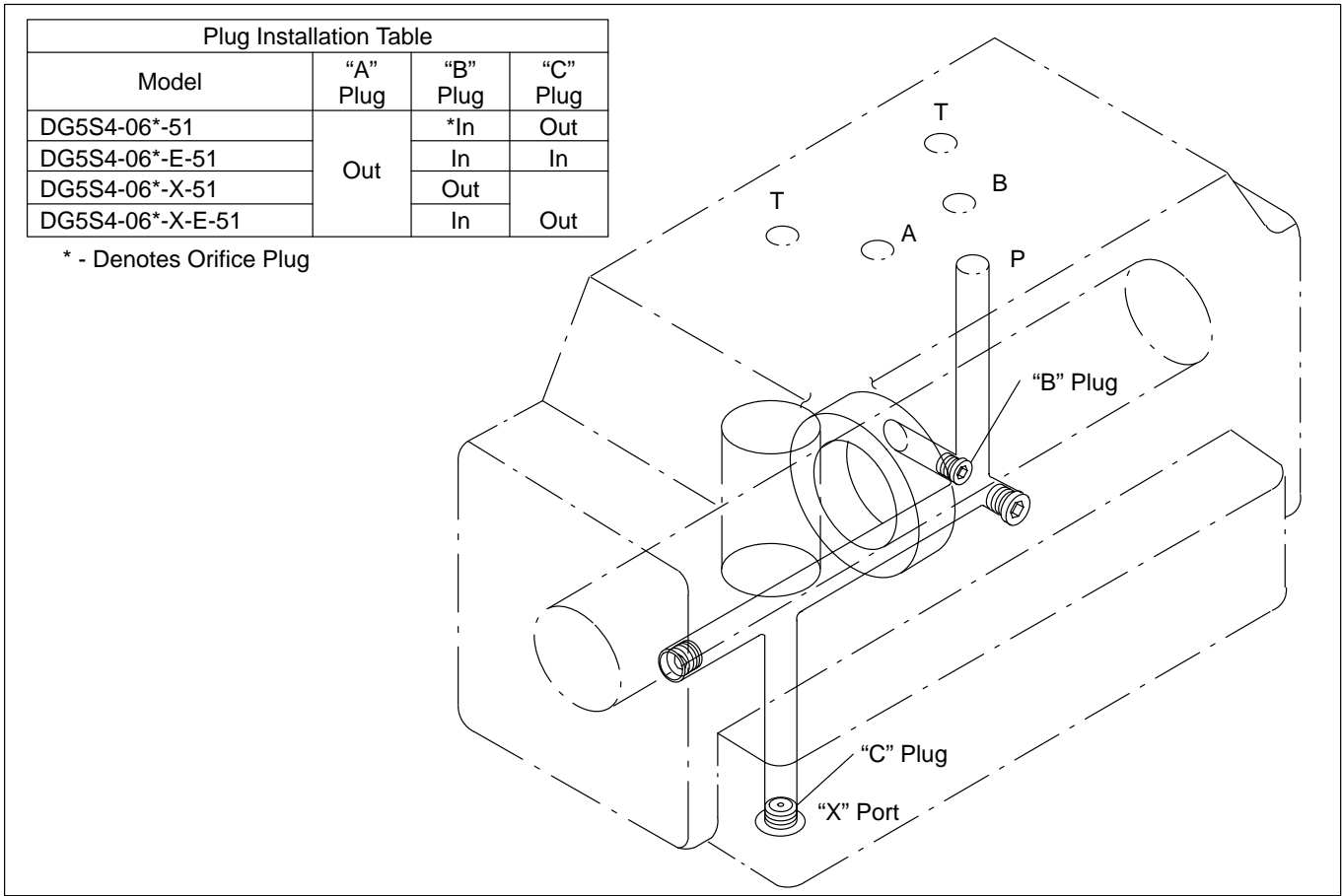

Figure 24a. DG5S4-06*-51 or DG5S4-06*-D-52 Internal Pressure Passages & Plug Locations

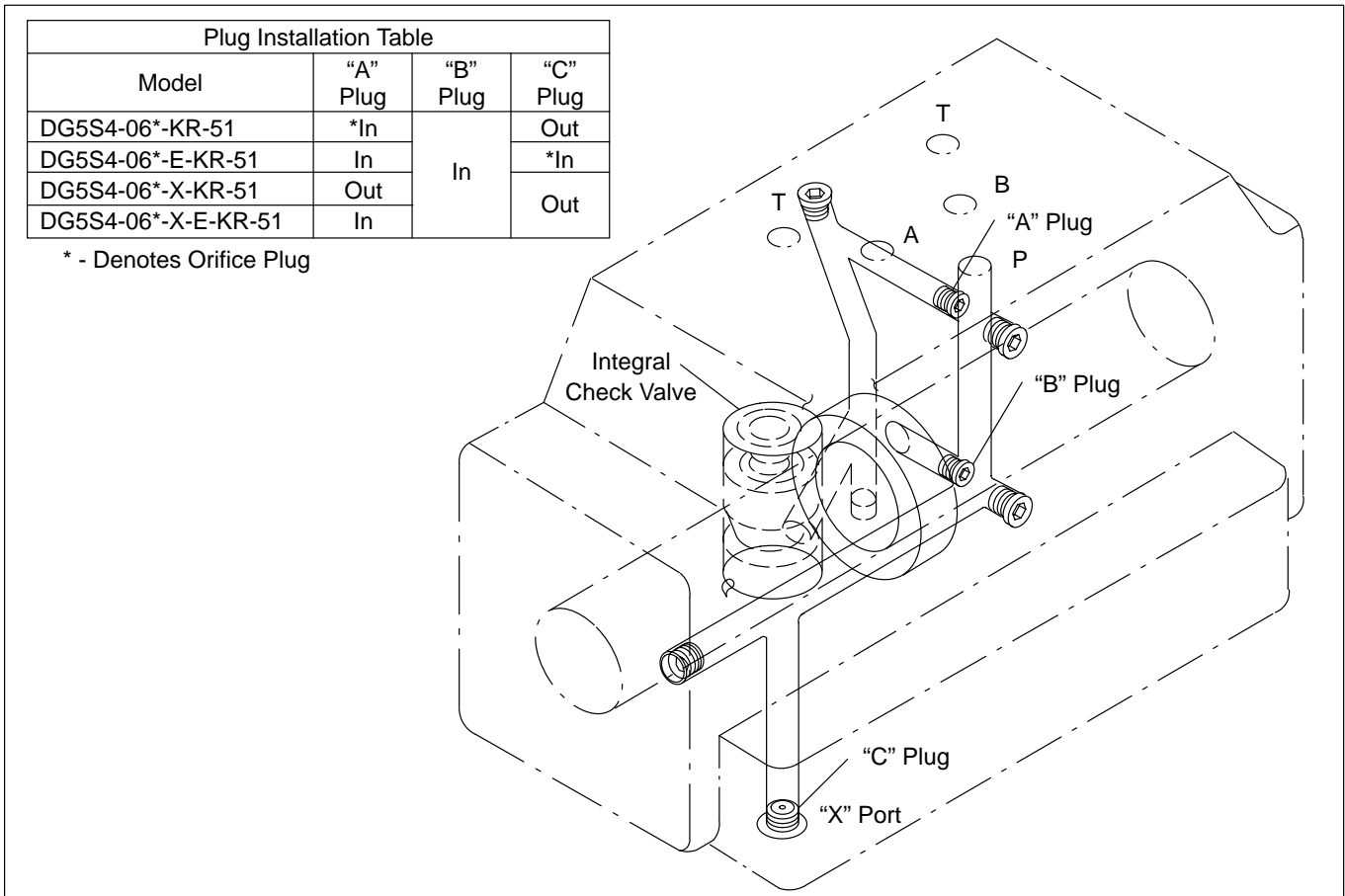

Figure 24b. DG5S4-06*-(K/R)-51 Internal Pressure Passages & Plug Locations

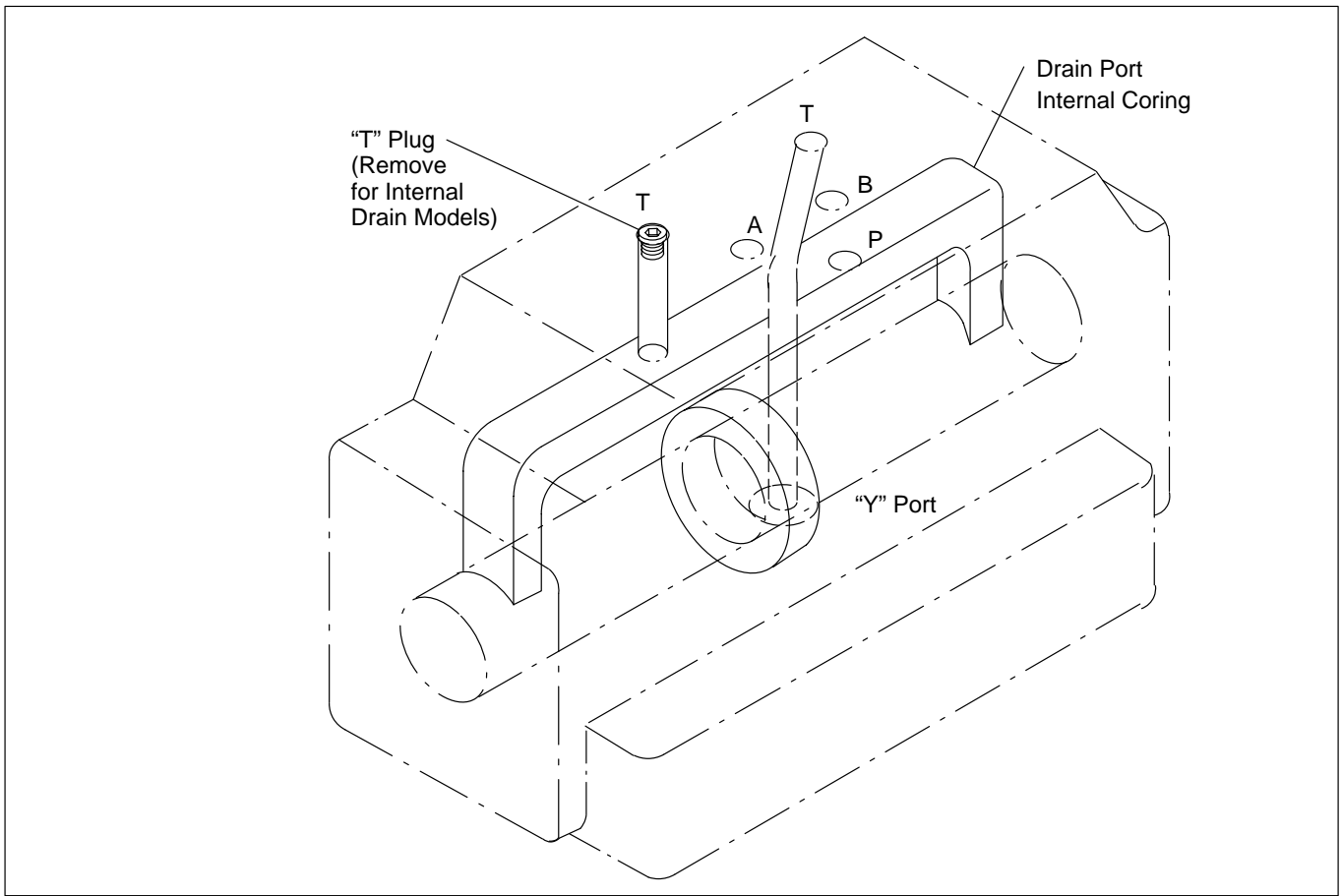

Figure 24c. DG5S4-06-T-51 Internal Drain Passages & Plug Locations

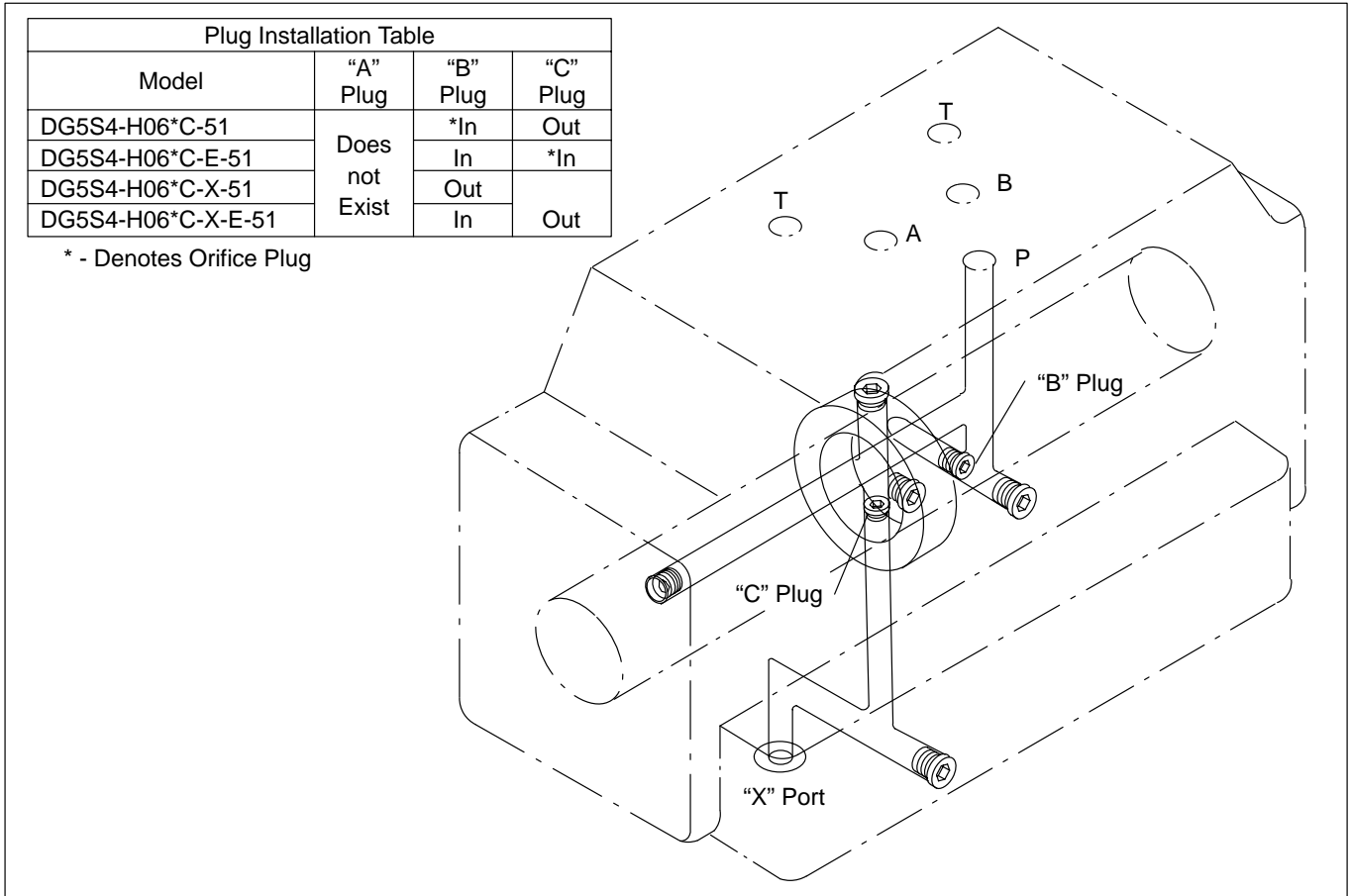

Figure 25a. DG5S4-H06-*-51 Internal Pressure Passages & Plug Locations

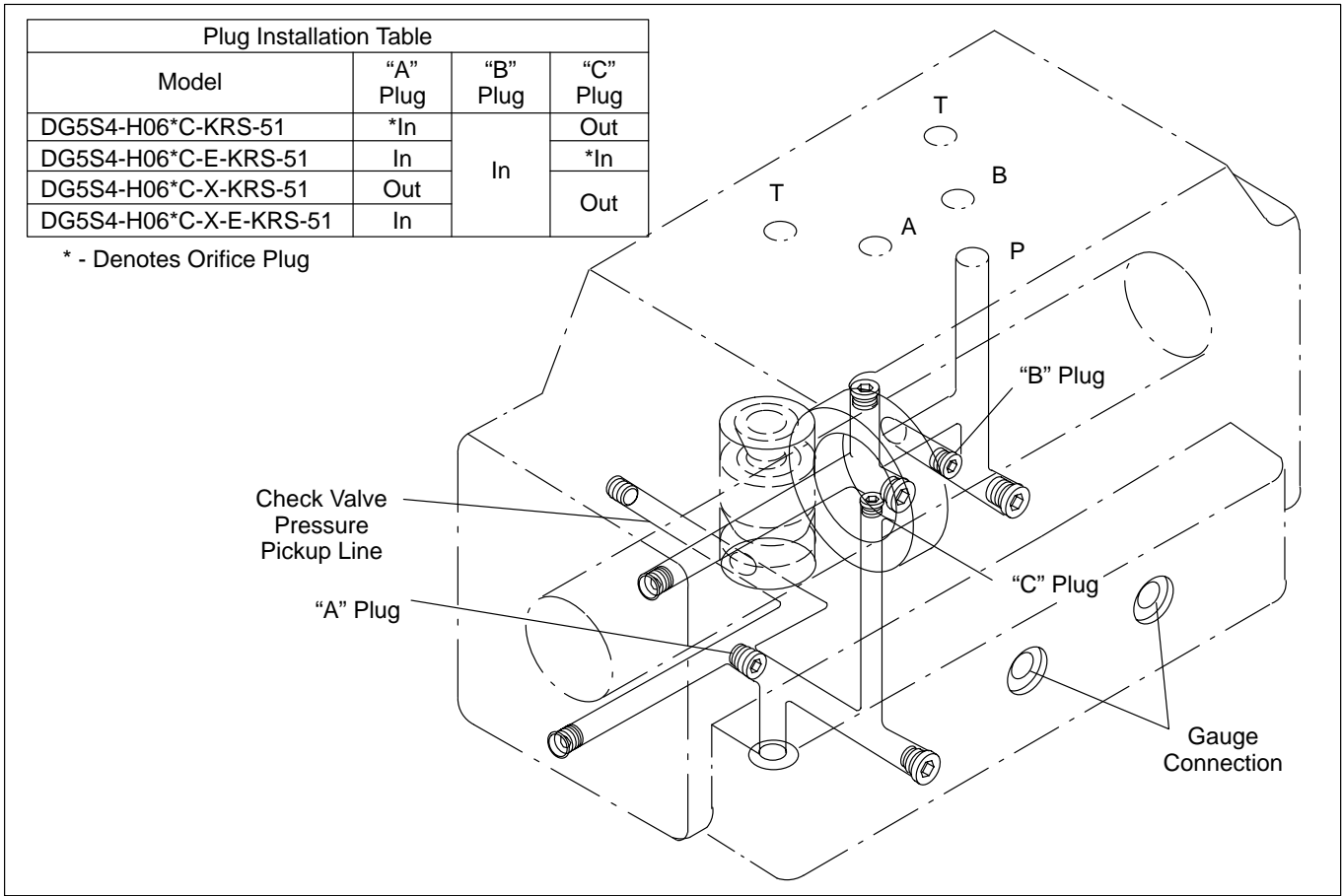

Figure 25b. DG5S4-H06-(K/R/S)-51 Internal Pressure Passages & Plug Locations

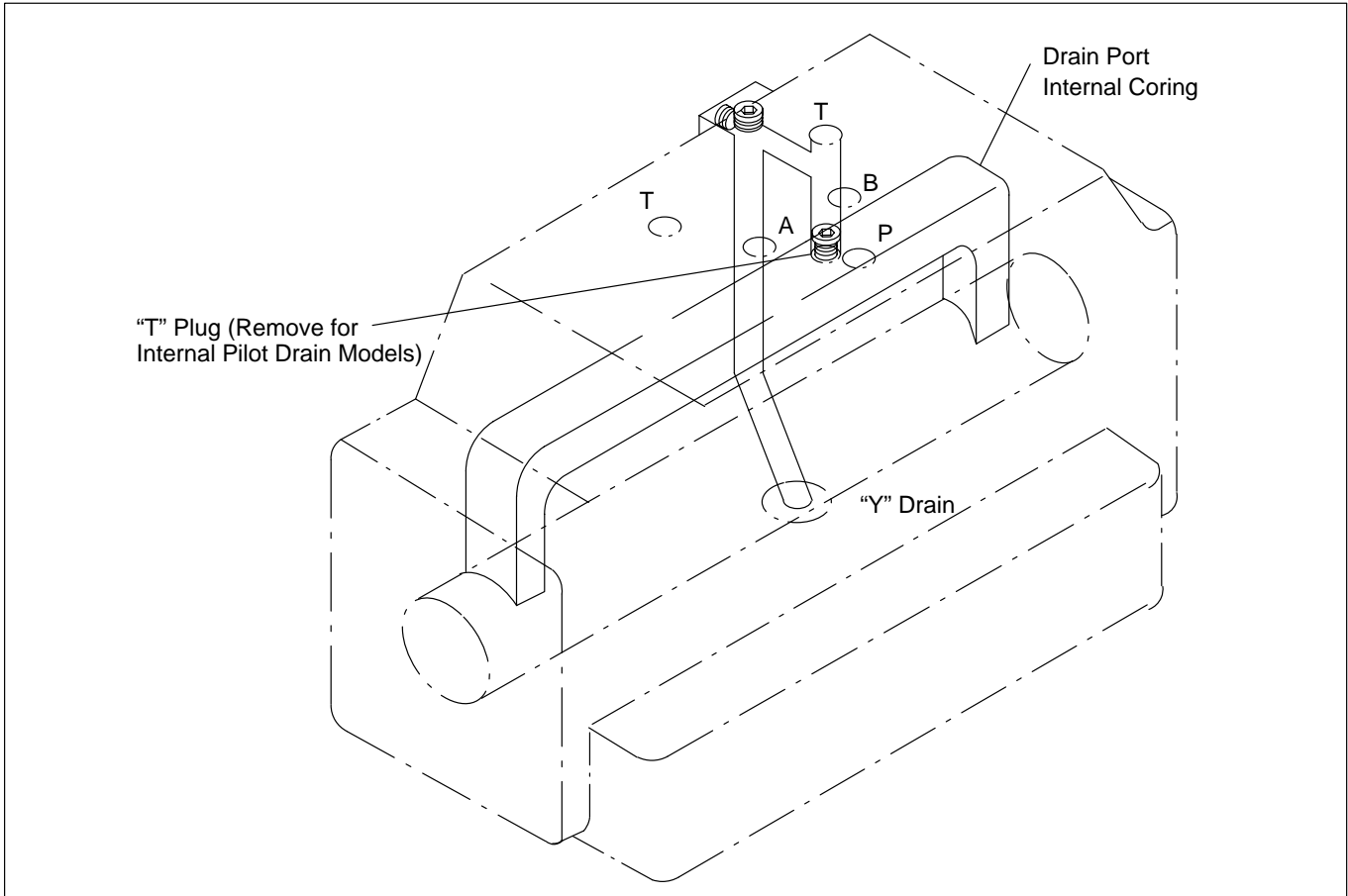

Figure 25c. DG5S4-H06-T-51 Internal Drain Passages & Plug Locations

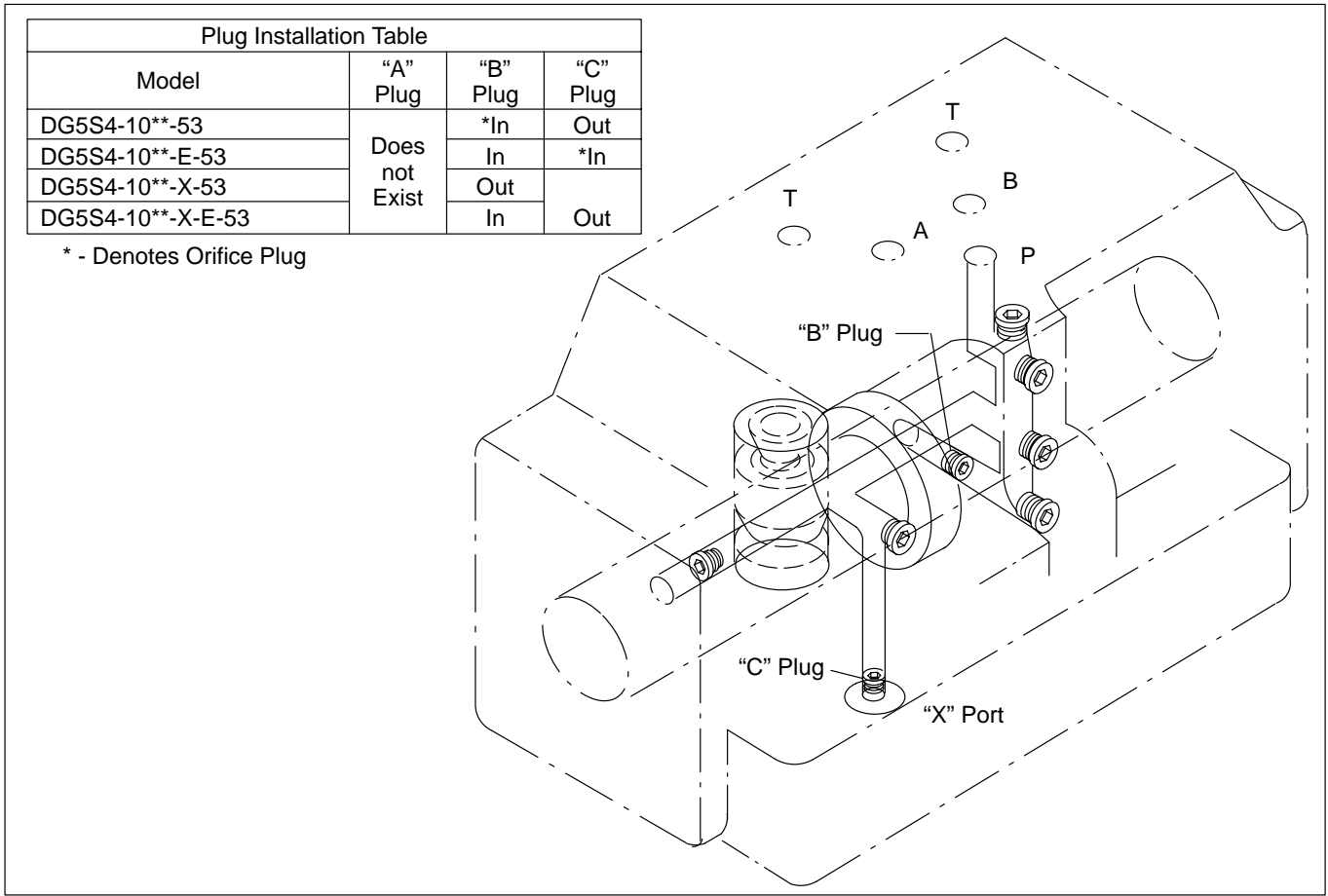

Figure 26a. DG5S4-10**-53/54 Internal Pressure Passages & Plug Locations

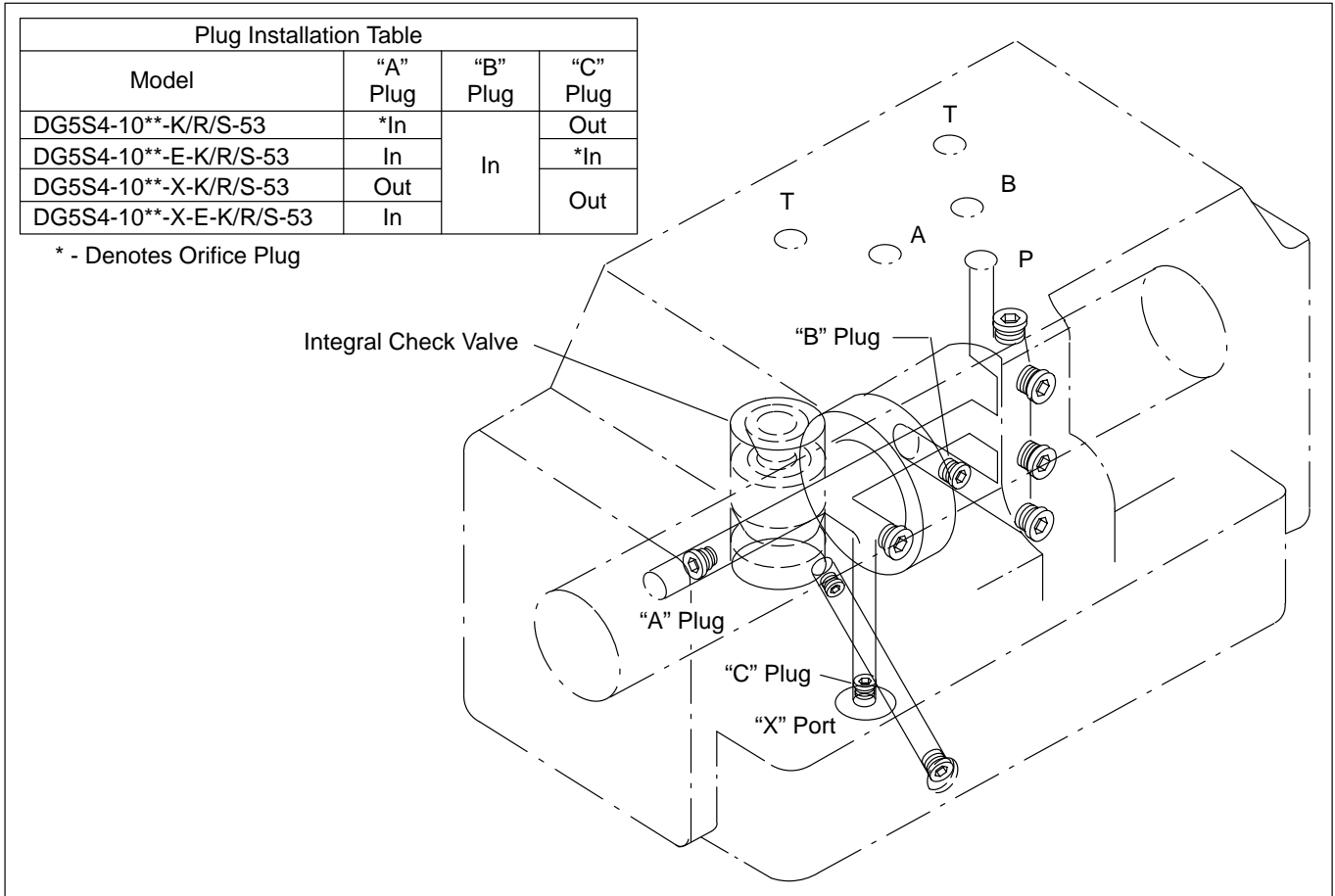

Figure 26b. DG5S4-10**-(K/R/S)-53 Internal Pressure Passages & Plug Locations

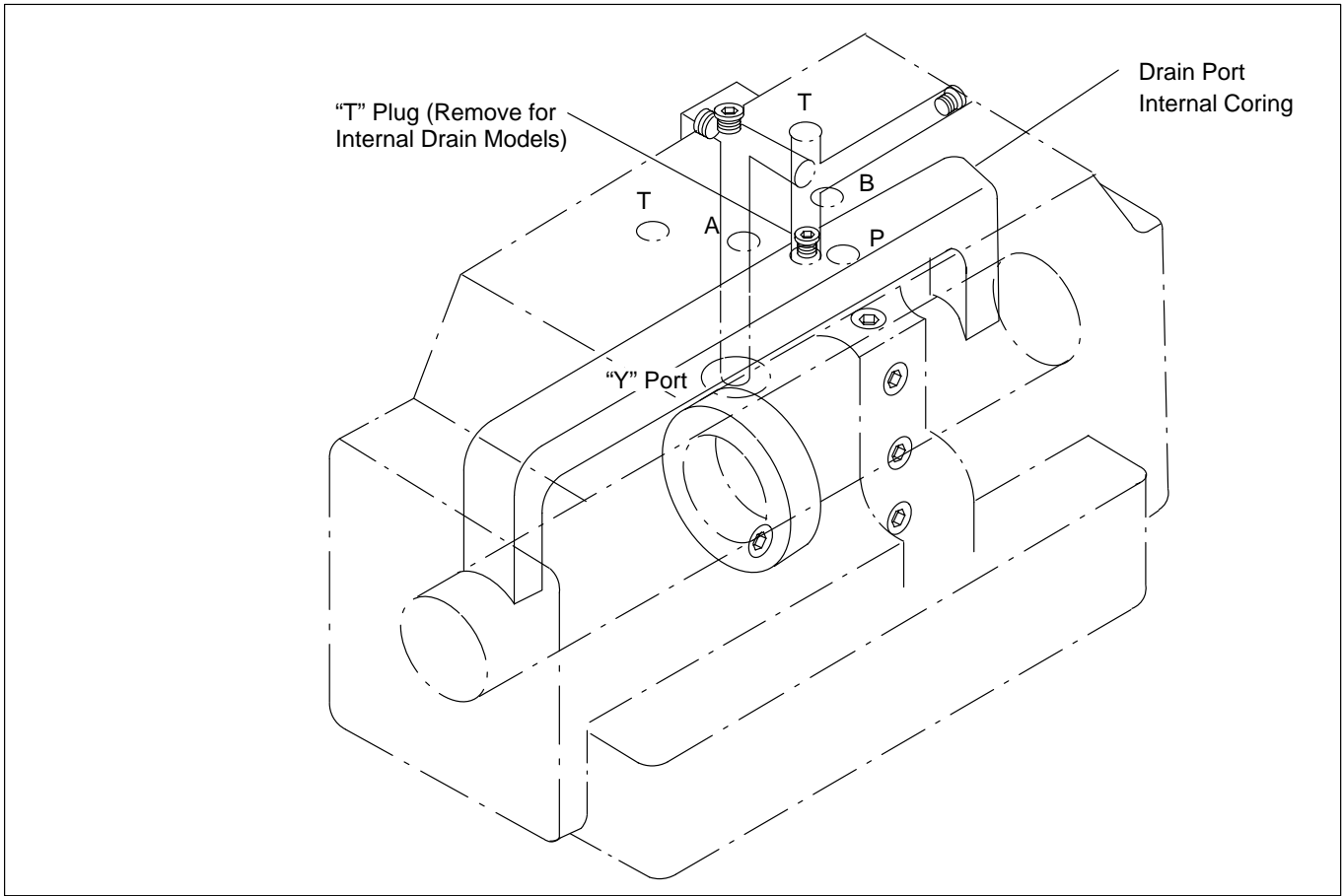

Figure 26c. DG5S4-10**-T-53 Internal Drain Passages & Plug Location

Plug Installation Table			
Model	"A" Plug	"B" Plug	"C" Plug
DG5S-8-**-10	Does not Exist	*In	Out
DG5S-8-**-E-10		In	*In
DG5S-8-**-X-10		Out	Out
DG5S-8-**-X-E-10		In	

* - Denotes Orifice Plug

This diagram shows a hydraulic valve with internal pressure passages. A 'P' Port is located on the top surface. A 'B' Plug is shown being inserted into a passage on the side. A 'C' Plug is shown being inserted into a passage on the bottom surface. Other ports labeled A, B, P, and T are also visible.

Figure 27a. DG5S-8-*-10 or DG5S-H8-*-20 Internal Pressure Passages & Plug Locations

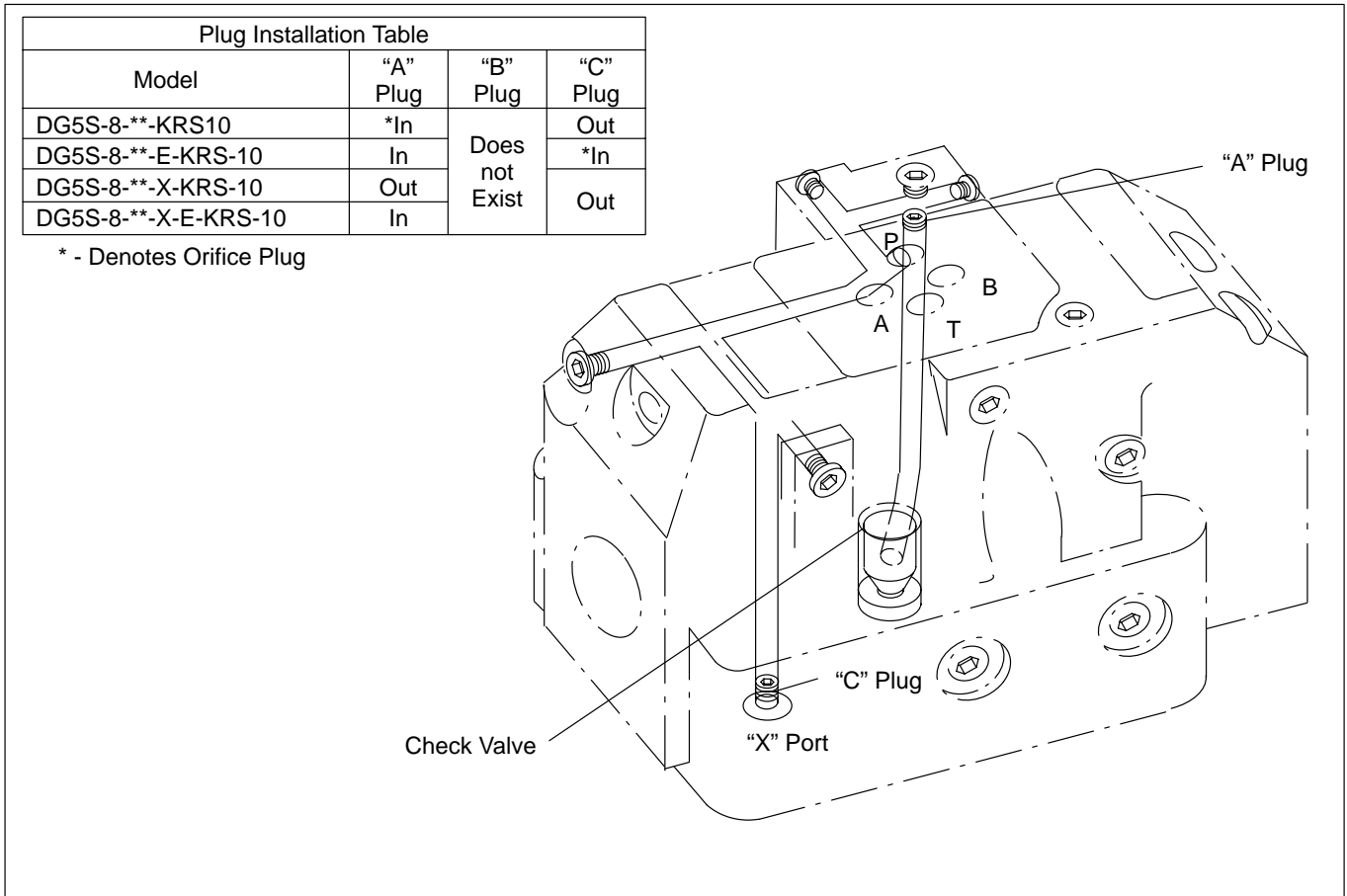

Figure 27b. DG5S-8-** (K/R/S)-10 or DG5S-H8-**(K/R/S)-20 Internal Pressure Passages & Plug Locations

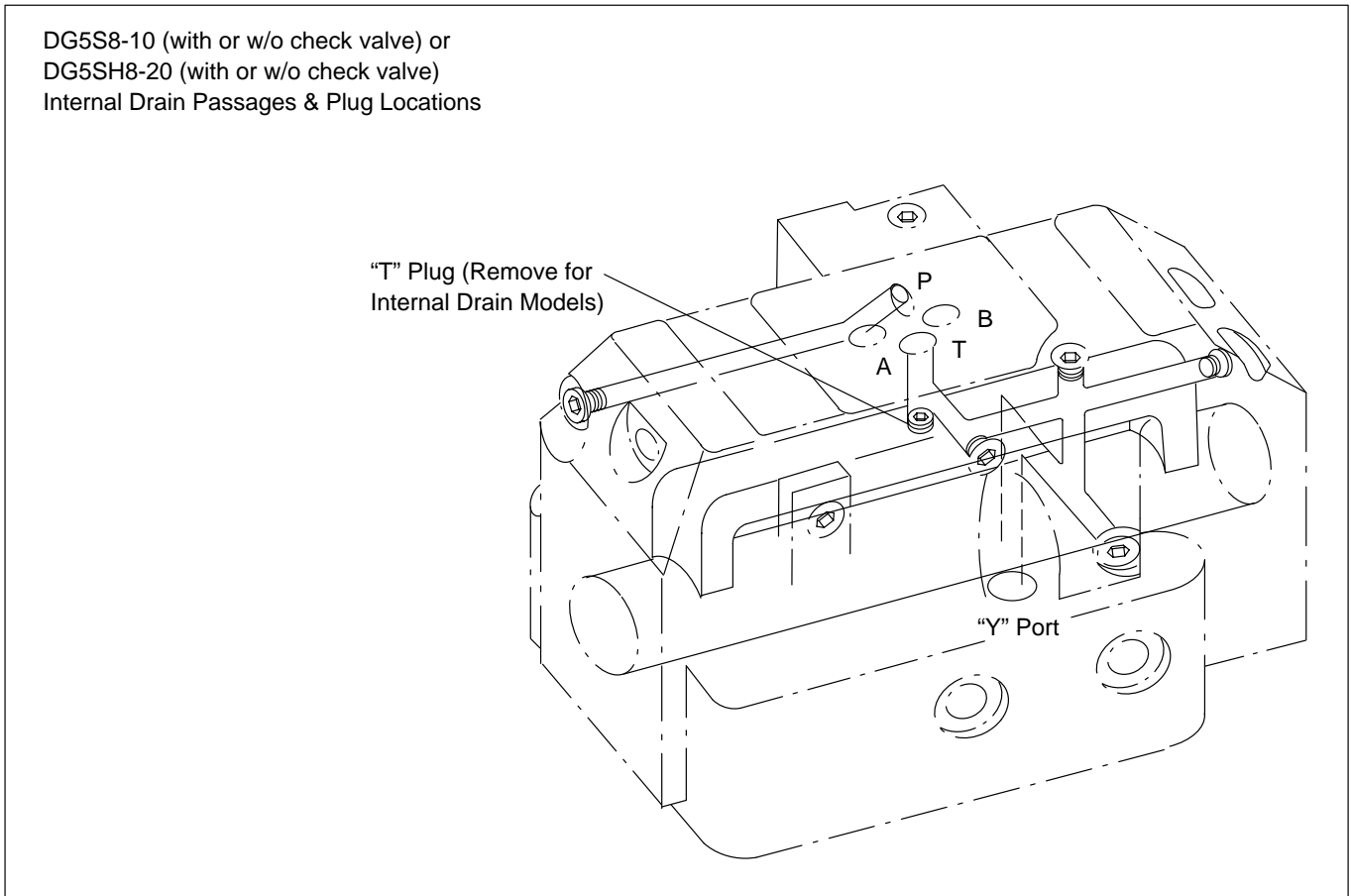

Figure 27c. DG5S8-**-10 or DG5S-H8-**-20 Internal Drain Passages & Plug Locations